

**Interval Finite Element Analysis for Load Pattern & Load Combination**

**A Thesis  
Presented to  
The Academic Faculty**

**By**

**Vishal Saxena**

**In Partial Fulfillment  
Of the Requirements for the Degree  
Master of Science in School of Civil & Environmental Engineering**

**Georgia Institute of Technology  
August 2003**

**Copyright © 2003 by Vishal Saxena**

# Interval Finite Element Analysis for Load Pattern & Load Combination

Approved by:

---

**Dr. Rafi Muhanna, Advisor**

---

**Dr. Abdul-Hamid Zureick**

---

**Dr. David Scott**

08/12/03 Date Approved

---

**To  
My Parents,  
Past, Present and Future**

## **ACKNOWLEDGEMENTS**

First and foremost I would like to thank my family for their invaluable and endless support that they have maintained over such long distances.

I would like to express my deepest gratitude to my advisor Dr. Rafi L. Muhanna. His guidance and confidence in me made this endeavor possible. His knowledge, personality, great sense of humor, and endless efforts to teach me and keep me motivated were extremely influential in the accomplishment of this work.

I offer my sincere thanks to the members of my thesis committee, Dr. Abdul-Hamid Zureick, Dr. David Scott, who provided helpful insight on the content and organization of this work.

I was fortunate to have close friends in Atlanta who were always there for me and whose support and friendship never faded. Their encouragement, friendship and all the shared memories will never be forgotten.

In the end, I wish to acknowledge my teachers who patiently taught me and shared their knowledge that laid the foundation, which I could build on.

# TABLE OF CONTENTS

ACKNOWLEDGEMENT	IV
TABLE OF CONTENTS	V
LIST OF TABLES	VII
LIST OF FIGURES	IX
SUMMARY	XII
CHAPTER 1 INTRODUCTION	1
CHAPTER 2 LOAD COMBINATIONS AND LOAD PATTERNS	4
2.1 LOAD COMBINATIONS	4
2.2 LOAD PATTERNS	6
CHAPTER 3 INTERVAL ARITHMETIC	20
CHAPTER 4 INTERVAL FINITE ELEMENT ANALYSIS	25
CHAPTER 5 LOAD TYPES AND INTERVAL TREATMENT	29
CHAPTER 6 C++ PROGRAM AND A TEST RUN	33
CHAPTER 7 INTERVAL ANALYSIS VS CONVENTIONAL ANALYSIS: LOAD COMBINATIONS AND LOAD PATTERNS	43
7.1 FORMULATION	44
7.1.1 FRAME DATA	46
7.1.2 LOAD TYPE/ COMBINATIONS	47
7.2 LOAD COMPUTATION	48
7.2.1 DEAD LOAD AND LIVE LOAD	48
7.2.2 EARTHQUAKE LOAD	48
7.2.3 WIND LOAD	51
7.3 COMPARATIVE ANALYSIS FOR LOAD PATTERNS AND LOAD COMBINATIONS	57
7.3.1 MAXIMUMUM SPAN MOMENT IN A BEAM	57
7.3.2 MINIMUM SPAN MOMENT IN A BEAM	58
7.3.3 END MOMENT IN A COLUMN	59

CHAPTER 8 COMPARATIVE STUDY OF INTERVAL FE & CONVENTIONAL ANALYSIS: EFFECTS OF NUMBER OF FLOOR	76
CHAPTER 9 DISCUSSION	104
CHAPTER 10 CONCLUSIONS	112
APPENDIX	
REFERENCES	

## LIST OF TABLES

Table		
1	Interval finite element analysis results for three spans continuous beam	36
2	Interval load input for interval finite element analysis	40
3	Interval finite element analysis results for frame example (using C++ Program)	41
4	Conventional structural analysis results for frame example	42
5	Dead load and live load for frame in consideration	48
6	Computation of earthquake Load	49
7	Earthquake loads as statically equivalent joint load	51
8	Wind pressure calculations	53
9	Static equivalent of wind load	54
10	Summary of loads	55
11	Maximum span moment in beam	57
12	Minimum span moment in beam	59
13	End moment in column element 8 as an effect of live load pattern A, B and C	62
14	Axial force in column 8 as an effect of live load pattern A, B and C	63
15	Shear force in column 8 as an effect of live load pattern A, B and C	64
16	End moment in column 1 as an effect of live load A, B and C	66
17	Axial force in column 1 as an effect of live load pattern A, B and C	67
18	Shear force in column 1 as an effect of live load pattern A, B and C	68
19	End moment in column element 4 as an effect of live load pattern A, B and C	69
20	Axial force in column element 4 as an effect of live load pattern A, B and C	70
21	Shear force in column 4 as an effect of live load pattern A, B and C	71
22	End moment in column 7 as an effect of live load pattern A, B and C	72
23	Axial force in column 7 as an effect of live load pattern A, B and C	73
24	Shear force in column 7 as an effect of live load pattern A, B and C	74

25	Earthquake load calculation for modified frame (ten floor frame)	77
26	Wind Load Calculation for modified frame (ten floor frame)	78
27	Summary of Earthquake Load and Wind Load for modified frame (ten floors)	79
28	Maximum span moment in beam 64(ten floor frame)	83
29	Minimum span moment in beam 64 (ten floor frame)	84
30	End moments in column 8 as an effect of live load pattern A, B and C (ten floor frame)	87
31	Earthquake Load calculation for modified frame (fifteen floors frame)	91
32	Wind load calculation for modified frame (fifteen floors frame)	92
33	Summary of earthquake load and wind load for modified frame (fifteen floors frame)	92
34	Maximum span moment in beam 64 (fifteen floors frame)	96
35	Minimum span moment in beam 64 (fifteen floor frame)	98
36	End moment in column 8 as per effect of live load pattern A, B and C (fifteen floor frame)	101
37	Effect of floors on percentage deviation of conventional response from interval response for beam 64	104
38	Effect of floors on percentage deviation of conventional response from interval response for column 8	107

## LIST OF FIGURES

Figure		
1.1a	Influence line for maximum positive reaction at support 1	8
1.1b	Load Pattern for maximum positive reaction at support 1	8
1.2a	Influence line for maximum negative reaction at support 1	8
1.2b	Load Pattern for maximum negative reaction at support 1	8
1.3	Sign convention for positive and negative bending moment	9
1.4a	Influence line for maximum positive moment at support 2	8
1.4b	Load Pattern for maximum positive moment at support 2	9
1.5a	Influence line for maximum negative moment at support 2	10
1.5b	Load Pattern for maximum negative moment at support 2	10
1.6	Sign convention for positive shear	10
1.7a	Influence line for maximum positive shear at section 7	11
1.7b	Load Pattern for maximum positive shear at section 7	11
1.8a	Influence line for maximum negative shear at section 7	11
1.8b	Load Pattern for maximum negative shear at section 7	11
1.9a	Influence line for maximum positive moment at section 7	12
1.9b	Load Pattern for maximum positive moment at section 7	12
1.10a	Influence line for maximum negative moment at section 7	12
1.10b	Load Pattern for maximum negative moment at section 7	12
2.1a	Load Pattern for maximum positive shear at mid-span of AB	13
2.1b	Load Pattern for maximum positive shear at mid-span of AB	13
2.2a	Load Pattern for maximum negative shear at mid-span of AB	14
2.2b	Load Pattern for maximum negative shear at mid-span of AB	14
2.3a	Load Pattern for maximum positive moment at section B	14
2.3b	Load Pattern for maximum positive moment at section B	14
2.4a	Rigid Frame, qualitative sketch of influence line	16
2.4b	Live load pattern for negative moment at point section A	17
3.1	Dead load presence on a portal frame	29

3.2	Live load presence on a portal frame (check-board pattern)	30
3.3	Earthquake Load (Static Equivalent) presence on a portal frame	31
4.1a	Finite Element consisting five nodes and six frame element	35
4.1b	Moment envelope for all possible live load pattern (GTSTRUDL)	36
5	Finite element consisting five nodes and six frame element	39
6.1	Typical floor plans	44
6.2	Six bay seven floor portal frame in consideration	45
6.3	Joints numbering for seven-floor frame	46
6.4	Frame elements numbering for seven-floor frame	46
7	Sign convention for positive and negative bending moment	56
7.1	Case 1: Live load pattern for maximum span moments in beam elements	57
7.2	Case 2: Live load pattern for minimum span moments in beam elements	58
7.3	Case 3: Live load pattern A for maximum/minimum end moment in a column	60
7.4	Case 3: Live load pattern B for maximum/minimum end moment in a column	60
7.5	Case 3: Live load pattern C for maximum/minimum end moment in a column	61
8.1	Joint numbering for ten floors portal frame	80
8.2	Frame element numbering for ten floors portal frame	81
9.1	Case 1: Live load pattern for maximum span moment in beam element – ten floors frame	82
9.2	Case 2: Live load pattern for minimum span moment in a beam element – ten floors frame	84
9.3	Case 3: Live load pattern A for end moment at the end of column 8 – ten floors frame	86
9.4	Case 3: Live load pattern B for end moment at the end of column 8	88

	– ten floors frame	
9.5	Case 3: Live load pattern C for end moment at the end of column 8	89
	– ten floors frame	
10.1	Joint numbering for fifteen-floor portal frame	93
10.2	Frame Elements numbering for fifteen floors portal frame	94
11.1	Case 1: Live load pattern for maximum span moment in beam element – fifteen-floor frame	95
11.2	Case 2: Live load pattern for minimum span moment in beam element – fifteen-floor frame	97
11.3	Case 3: Live load pattern A for maximum/minimum end moment in column 8 – fifteen floors frame	99
11.4	Case 3: Live load pattern B for maximum/minimum end moment in column 8 – fifteen floors frame	100
11.5	Case 3: Live load pattern C for maximum/minimum end moment in column 8 – fifteen floors frame	102
12a	Maximum and Minimum Span Moment in Beam 64 - Percentage deviation Vs number of floor for load combination $1.2 D + 1.6 L$	105
12b	Maximum and Minimum Span Moment in Beam 64 - Percentage deviation Vs number of floor for load combination $1.2 D + L$	106
13a	Bounds on End Moment in Column 8- Percentage Vs number of floor for load combination $1.2D+1.6L$	109
13b	Bounds on End Moment in Column 8- Percentage Vs number of floor for load combination $1.2D+1.0L+1.6W$	110
13c	Bounds on End Moment in Column 8- Percentage Deviation Vs number of floor for load combination $1.2D+1.0E2+L$	110

## SUMMARY

In this thesis, Interval finite element analysis is being compared with conventional load pattern analysis to predict the critical response of a given structure under various load combinations. Different load combinations and load patterns that have been widely accepted by structural engineering code practices until date are being considered. The limitations of such conventional tools will be highlighted and the advantages of Interval finite element analysis over existing tools shall be explored.

Interval finite element analysis is being shown as an efficient tool to analyze large and complicated structures which otherwise are impossible to be analyzed for all possible load patterns and load combinations. Initial developments in the area of interval arithmetic will be discussed. In order to deal with uncertainty associated with the presence of live loads, the idea of load being represented as interval quantities will be introduced. Basics of interval finite element analysis will be extracted from recent research developments. Implementation in the form of a computer program will be performed and a comparative analysis of a real portal frame will be considered in order to show the advantages of interval finite element analysis over traditionally available load pattern analysis methods.

In general, interval responses always bound corresponding response obtained from conventional load pattern analysis. Such interval enclosure of the conventional results will be shown first through analyzing a six-bay and seven-floor portal frame and later through extending the same frame to ten and fifteen floors frame.

It is also shown that load factors can be used as interval quantities. Interval load factor quantities contain all the load combinations and load patterns in it and can capture the critical response of the structure that is obtained from the interval finite element analysis of the structure for all the load combinations.

In general, interval finite element enclosure comes with sharp and guaranteed results. Situations have been identified where the deviation between conventional load pattern analysis and bounds obtained through interval finite element analysis may be significant. In such cases conventional load pattern analysis will be totally underestimating structural response. .

Interval finite element analysis deals with interval operations as such, special computational tools are needed. Such tools are easy to develop in the form of a computer program, and the current thesis work focuses on a computer program that is capable of analyzing a frame element structure for concentrated and uniformly distributed loads. Similarly, once comprehensive and user friendly software are in place, it will be easy to adopt such techniques for real world structures. The engineer will be able to estimate critical response of the given structure for given load combination without investing much time and effort.

# 1. INTRODUCTION:

In structural engineering practice, individual structural members are designed for the critical scenarios. Conventionally such critical scenarios are being identified using structural analysis for different load combinations.

Live loads such as human occupancy floor loads can be placed in various ways, some of which will result in larger effects than others. Hence, from a live load point of view we need to analyze a given structure for all possible placements of loads. Such placements of loads are known as load patterns. It is easy to see that the number of live load patterns needed in order to find the true critical response of the structure increases exponentially with an increase in the number of structural elements. Hence, the analysis of structures under all possible live load patterns becomes increasingly difficult or impossible for complex multidimensional systems.

Conventionally dead loads, live loads, earthquake loads and wind loads are the primary load types used to analyze a structure for various parameters like span moments, end moments, shear, thrust or deflections. The Muller Breslau Principle for influence lines is an effective way to obtain critical load patterns. Realizing the fact that the efforts required in solving large structures is too much and such efforts further increase as design demands multiple analysis of the structure. In a way, such conventional analysis tools prove to be realistic only in a qualitative sense.

Further, combining load combinations and load patterns requires the engineer to do multiple iterations of structural analyses in order to capture the critical scenario. Apart from being an impractical task in most situations, it is impossible at times. In fact for

simplicity standard structural engineering codes of practice have suggested several critical load patterns. In practice, engineers have limited themselves to suggested critical load patterns (ASCE02/ACI02/UBC/IBC). It is important to emphasize that these load combinations are just an effort in order to avoid large number of structural analysis and critical scenarios need not necessarily occur under such load combination and load patterns. In such cases engineers are supposed to make their own judgment and they have to take the risk of missing such critical cases.

Current thesis work is an effort to show that Interval arithmetic provides a simple, easy, exact and efficient way of solving structural problems of all sorts of complexities under all possible load patterns and load combinations. It is interesting to find that interval finite element analysis is capable of producing results in a quantitative manner.

In general an interval finite element analysis can be used as an efficient tool to handle uncertainties of all sorts of the system parameters (such as uncertain material properties or uncertain geometry); however, this work has been limited to deal with load patterns and load combinations. Since the live load may or may not be present at a particular location, uncertainty in the location of live load can be modeled as an interval load. Effectively live loads may be introduced as interval with bound values between zero and its full value. Interval finite element analyzes structure under the application of such loads. It will be shown that critical response will always be contained within the interval response of structure.

Before interval finite element analysis and its application to deal with live load pattern and load combinations, is discussed in detail, a review of conventional load pattern analysis adopted so far, needs to be performed. Limitations for use of such conventional

tools will be underlined. Later in subsequent sections interval finite element analysis will be introduced in order to overcome the disadvantages associated with traditional tools to deal with load uncertainty and load combinations.

## 2. LOAD COMBINATIONS AND LOAD PATTERNS

### 2.1 Load Combinations

Traditionally, various structural engineering codes of practice have been suggested different load combinations that structural engineers need to consider for safe design of structure. Different structural engineering codes of practices, such as the American Concrete Institute (ACI), American Institute of Steel Construction (AISC), American Society of Civil Engineers (ASCE), Uniform Building Code (UBC) and International Building Code (IBC) suggest different load factors and load combinations.

However in recent years, particularly after the development of Load Resistance Factor Design (LRFD), attempts have been made in order to adopt same load factors and hence load combinations. Load factors have been refined and made more realistic by using tools like probabilistic risk and reliability analysis. It is important to note that currently ASCE 2002 and ACI 2002 both list down same set of load combinations. However, in the current thesis references will be restricted to the ACI Building code requirements and the ASCE. To illustrate this idea here are complete set of load combinations that are still being used in real practice.

1. Using load and resistance factor design (LRFD), ASCE-7, 98 suggests several important load combinations as

- $1.4D$
- $1.2D + 1.6L$
- $1.2D + (0.5L \text{ or } 0.8W)$
- $1.2D + 1.6W + 0.5L$

- $1.2 D + 1.0 E + 0.5 L$
- $0.9 D + 1.0 E$
- $0.9 D + 1.6 W$

2. Load combinations specified by ACI-02 are listed below:

- $1.4 D$
- $1.2 D + 1.6 L$
- $1.2 D + L$
- $1.2 D + 0.8 W$
- $1.2 D + 1.6 W + 1.0 L$
- $1.2 D + 1.0 E + 1.0 L$
- $0.9 D + 1.6 W$
- $0.9 D + 1.0 E$

In above mentioned load combinations:

D is the dead load.

L is the live load.

E is the earthquake load and

W is the wind load.

This implies that the engineer must analyze the structure under several load combinations and needs to design for the critical load combination. In practice, engineers use several load combinations in order to generate an envelope for a given structural parameter. These envelopes govern the design of that structure.

It is clear that such conventional approaches involve multiple analyses of the structure.

For complicated structures a single analysis may be very tiresome. Additionally due to

the iterative nature of the design process, the analysis part may take significant time and efforts.

Conversely, Interval finite element analysis provides an easier way to come up with such design parameters envelope. Load combinations can be thought of as combinations of presence and absence for certain types of load and can easily be modeled as an interval having bounds between zero and the full value of that type of load. The structure needs to be analyzed only once, and an envelope can be developed in terms of the bound on interval response of the structure. In coming sections we will discuss the process of determining the envelope through interval finite element approach in detail.

## **2.2 Load Pattern**

Live loads lead to a number of load patterns that identify different critical scenarios depending upon the structural parameter of interest. For a simple structure, it is feasible to perform an analysis under all possible load patterns and combinations. These analysis results can easily be assembled in order to obtain an envelope for the variation of the structural parameter in consideration. Such envelopes then can be used to determine critical value of various structural parameters.

However, as the number of structural elements in a structure increases (as in a multi-story structure), the number of possible live load patterns increase exponentially. These load patterns, when included in suggested load combinations further complicate analysis needed to find the critical scenario. Given that for real structures even a single structural analysis can be very time consuming, multiple analysis iterations become practically infeasible.

Figure 1.1 to 1.10 illustrates a five span beam under the application of live load. It is customary to think that engineer may be interested in values of reaction at support, maximum/ minimum moment at support, or mid-span, or in shear force at some section

For the five-span continuous beam in consideration, any of these five spans can be loaded completely or partially or even not loaded at all. For any load pattern considered, there is some critical scenario available for some or other structural parameter (see Figure 1.1b-1.8b). (These examples have been extracted from the article available at

<http://www.public.iastate.edu/~fanous/ce332/influence/homepage.html>)

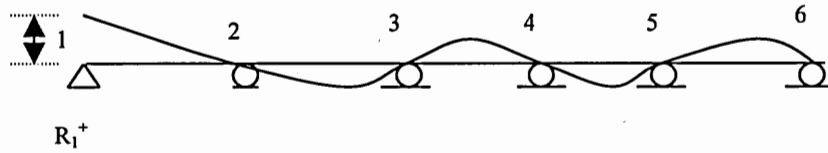
These load patterns can be generated using influence lines. Figure 1.1a to 1.10a show influence lines for various load patterns that leads to corresponding load patterns as shown in 1.1b to 1.10b. There are widely popular conventional tools to draw such influence lines such as Mueller-Breslau Principle.

One of the most important features of the Mueller-Breslau principle is that it allows influence lines to be sketched qualitatively. At times this can provide important information concerning load placement.

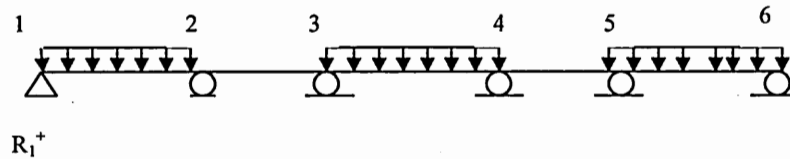
The Mueller-Breslau principle can be stated as follows:

*If a function at a point on a structure, such as the reaction, shear, or moment is allowed to act without restraint, the deflected shape of the structure, to some scale, represents the influence line of the function.*

Figure 1.1a shows the influence line for the positive reaction at support 1. Reaction acting vertically upward is being considered as positive reaction. The force acting vertically downward is being termed as negative reaction. Thus if live load is applied as shown in Figure 1.1b, it will lead to the maximum positive reaction at support 1.

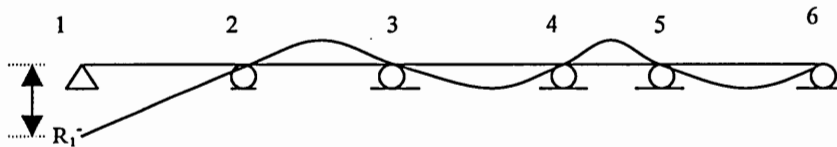


**Figure 1.1a. Influence Line for positive reaction at support 1**

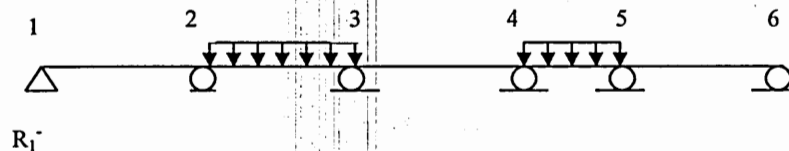


**Figure 1.1b. Load pattern for maximum positive reaction at support 1**

Similarly Figure 1.2b shows the influence line for the negative reaction at support 1. If live load is applied as shown in Figure 1.2b, it will lead to maximum negative reaction at support 1 respectively.

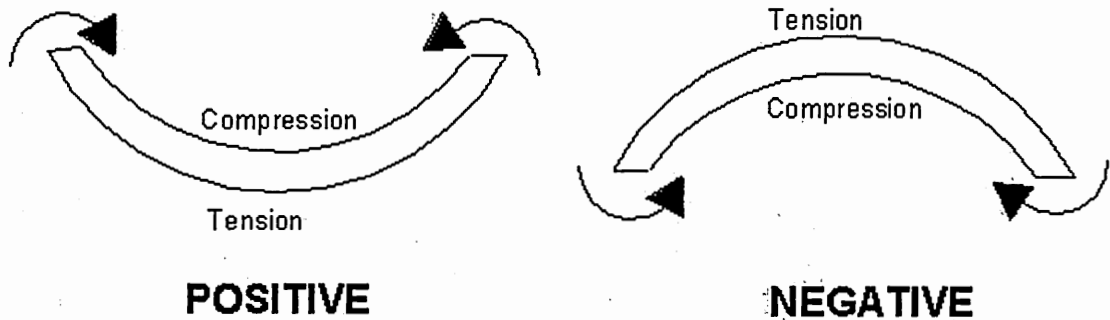


**Figure 1.2a. Influence Line for negative reaction at support 1**



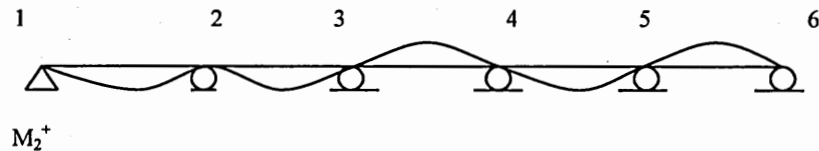
**Figure 1.2b. Load pattern for maximum negative reaction at support 1**

Next, influence lines are sketched qualitatively in Figure 1.4a and 1.5a for positive and negative moment at support 2. Moment causing tension at bottom is labeled positive moment and moment causing tension at top is labeled as negative (Figure 1.3).

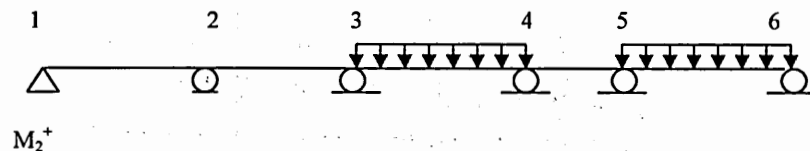


**Figure 1.3. Sign convention for positive and negative bending moment**

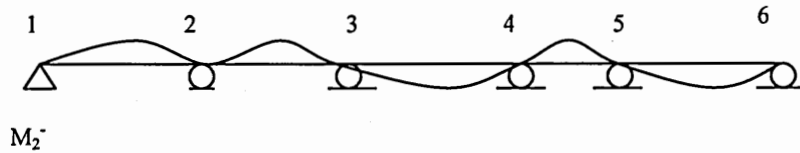
Figure 1.4b and 1.5b shows live load pattern needed to obtain maximum positive and negative moment at support 2.



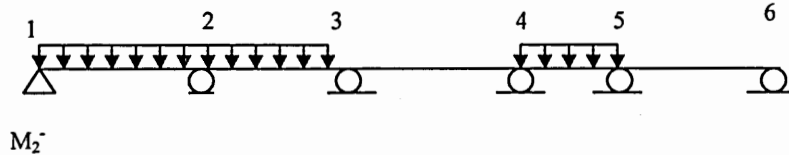
**Figure 1.4a. Influence Line for positive moment at support 2**



**Figure 1.4b. Load pattern for maximum positive moment at support 2**

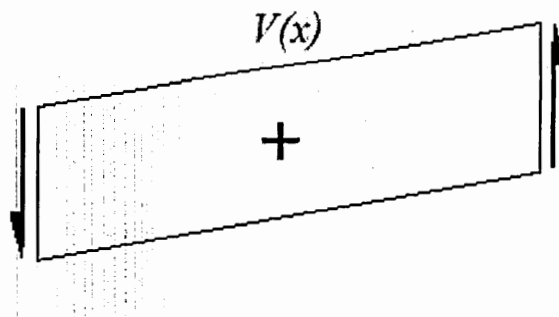


**Figure 1.5a. Influence line for negative moment at support 2**



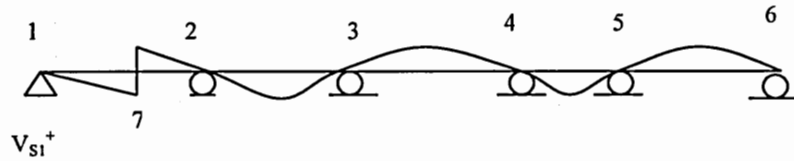
**Figure 1.5b. Load pattern for maximum negative moment at support 2**

Figure 1.7 to 1.10 focuses at section 7 that is located somewhere between section 1 and section 2. In these Figures (Figure 1.7, 1.8, 1.9 and 1.10) load patterns to obtain maximum positive shear, maximum negative shear, maximum positive moment and maximum negative moment at section 7. Sign convention for positive shear is shown in Figure 1.6.

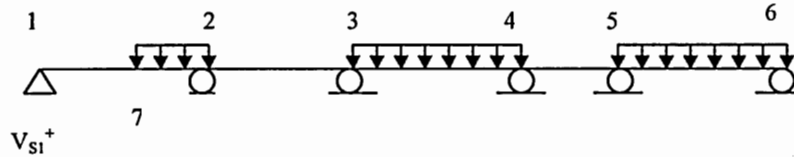


**Figure 1.6. Sign convention for positive shear**

The influence line for positive shear at section 7 is being shown in Figure 1.7a. Figure 1.7b shows corresponding live load pattern that maximizes positive shear at section 7.

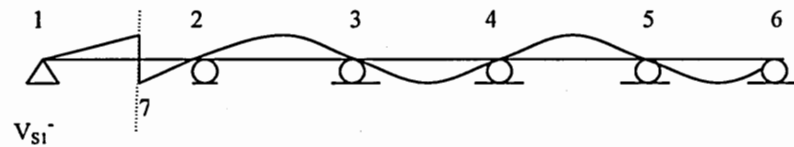


**Figure 1.7a. Influence line for positive shear at 7**

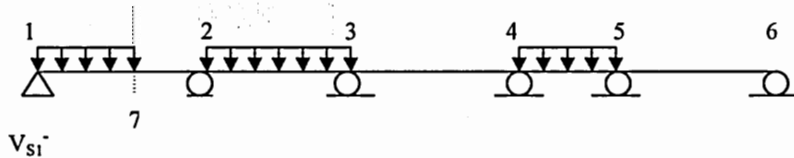


**Figure 1.7b. Load pattern for maximum positive shear at 7**

Figure 1.8a shows the influence line for negative shear at section 7. Negative shear at section 7 can be maximized if live loads are placed as shown in Figure 1.8b.

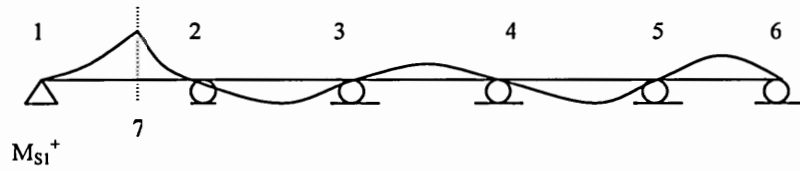


**Figure 1.8a. Influence line for negative shear at 7**

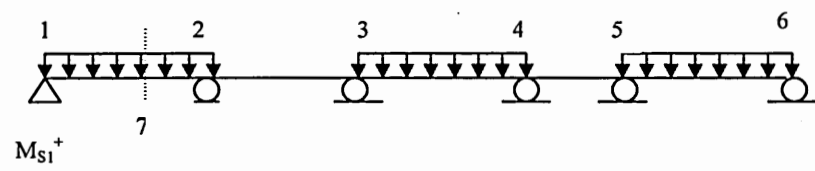


**Figure 1.8b. Load pattern for maximum negative shear at 7**

Figure 1.9a shows these influence lines for positive moment at section 7. Figure 1.9b shows live load pattern to obtain maximum positive moment at section 7.

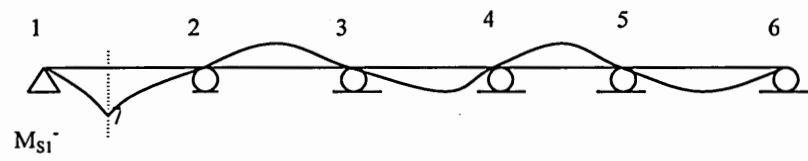


**Figure 1.9a. Influence line for positive moment at 7**

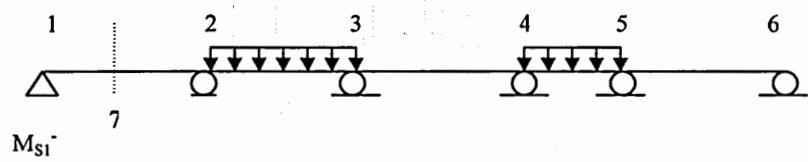


**Figure 1.9b. Load pattern for maximum positive moment at 7**

Figure 1.10a shows these influence lines for negative moment at section 7. Figure 1.10b shows live load pattern to obtain maximum negative moment at section 7.



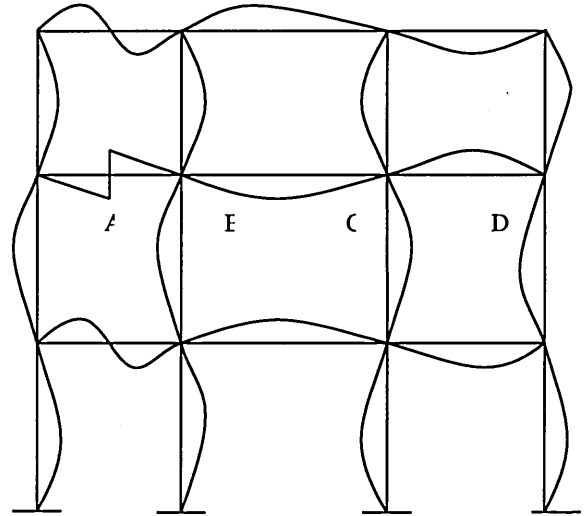
**Figure 1.10a. Influence line for negative moment at 7**



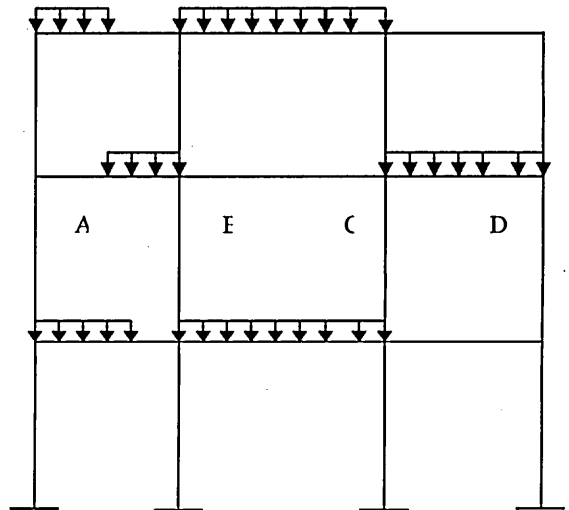
**Figure 1.10b. Load pattern for maximum negative moment at 7**

The afore-mentioned load patterns are not the only patterns possible, nor are these sufficient to determine all the critical cases. In order to analyze this beam completely, we need  $2^5$  (32) load patterns. It can be easily verified that the remaining 23 load patterns, once considered, will also lead to the critical value of some or other structural parameter. In order to ascertain the critical response of structure, a structural engineer needs to analyze it 32 times. It is apparent that the efforts increase exponentially as the number of span increase.

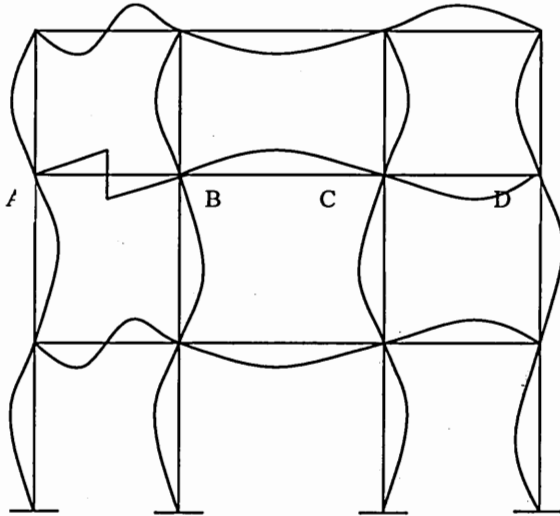
Another example can be demonstrated on the portal frame as shown in Figures 2.1b, 2.2b and 2.3b. Three of the load patterns have been chosen randomly for a three-bay and three-floor portal.



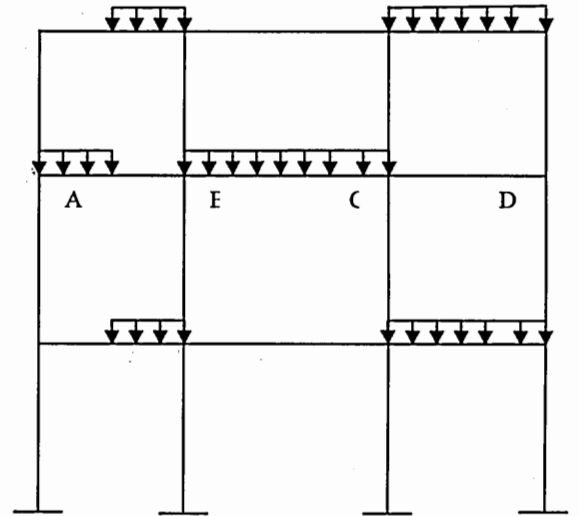
**Figure 2.1a. Influence line for positive shear at mid-span of AB**



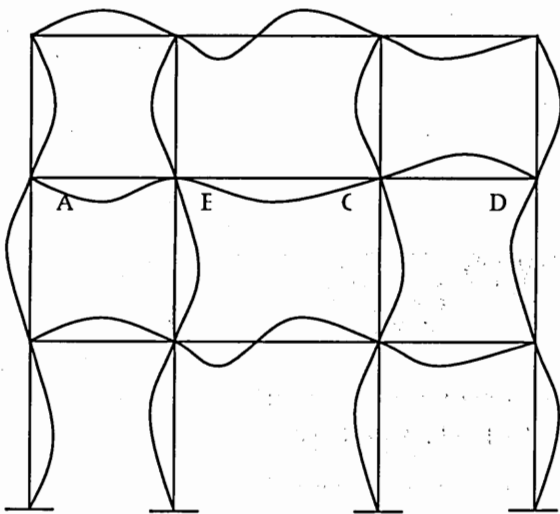
**Figure 2.1b. Load Pattern for maximum positive shear at mid-span of AB**



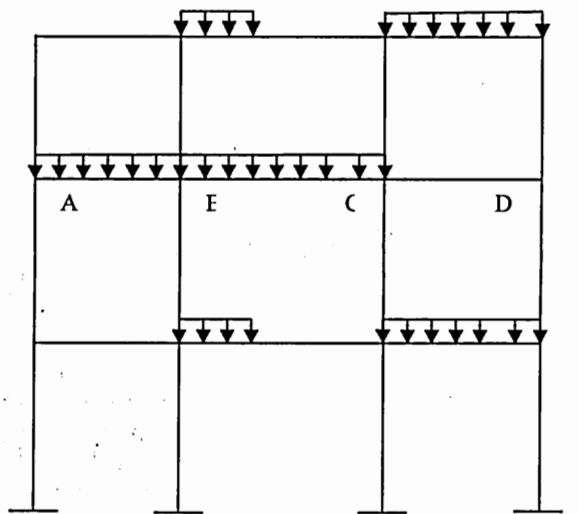
**Figure 2.2a. Influence line for negative shear at mid-span of AB**



**Figure 2.2b. Load Pattern for maximum negative shear at mid-span of AB**



**Figure 2.3a. Influence line for negative moment at B**



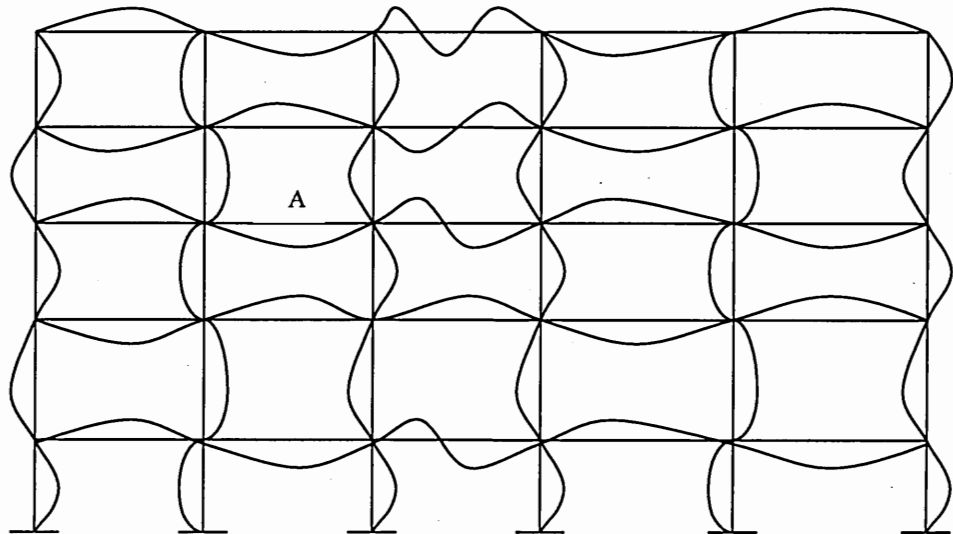
**Figure 2.3b. Load Pattern for maximum negative moment at B**

Figure 2.1b shows a typical live load pattern that an engineer will consider obtaining the maximum positive shear at the mid-span of the beam AB. Similarly, figure 2.2b shows the live load pattern used for maximum negative shear at the mid-span of beam AB. The live load pattern shown in Figure 2.3b is used to determine the maximum positive moment at joint B. Once again influence lines can be used in order to generate these load patterns.

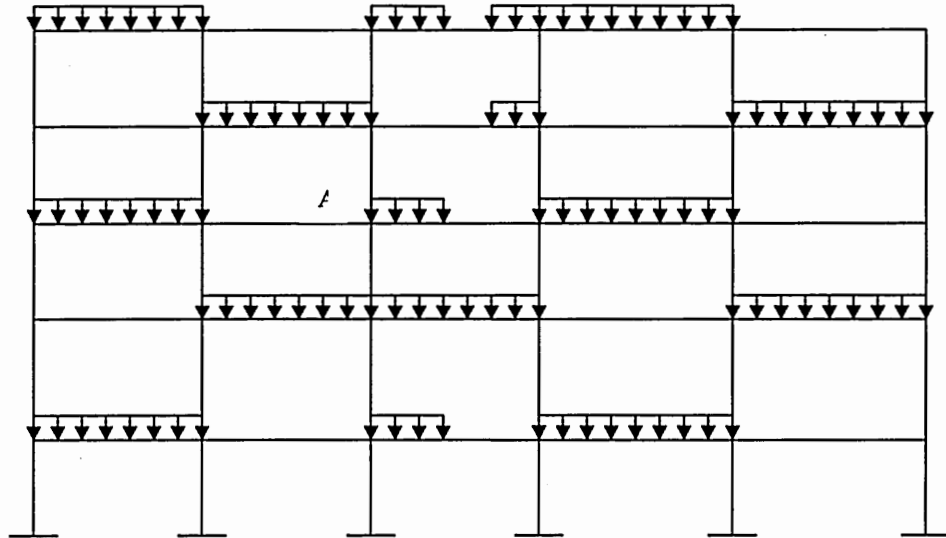
Figure 2.1a to 2.3a shows corresponding influence line diagrams. In order to draw influence lines for maximum positive shear at the mid-span of span AB, a unit displacement is being given assuming the presence of shear release right at the mid-span of beam AB. A qualitative sketch of deflection of the entire frame is shown in Figure 2.1a. It is important to note that constraint of all the joints must be maintained. This deflected shape of the frame gives the influence line for positive shear at the mid-span of the beam. In order to maximize positive shear at the mid-span of span, all those portions of the beam that have positive ordinate of the deflected curve, have to be loaded. This will be defined as the load pattern for maximum positive shear at the mid-span of beam AB. Similarly, figure 2.2a gives the influence line for negative shear at the mid-span of beam AB. It is important to note that this time qualitative deflected shape requires a shear release displaced in the opposite direction.

Figure 2.3a shows deflected shape of the frame for maximum negative moment at support B. In this case a moment release is provided at the section in consideration and a unit rotation is imposed on release. Deflected shape of the frame will give the influence line for moment at that section.

Finally, consider the rigid frame shown in figure 3.1 that might represent a portion of a reinforced concrete building. It is usual to consider both dead load (the weight of the structure, superimposed dead load) as well as live load (people, equipment, furniture) in the design of a structure; there is of course, no question concerning the placement of dead load since it must be placed wherever it occurs and it remains there forever. Live load, on the other hand, must be placed in such a manner as to produce the most critical effect.



**Figure 2.4a. Rigid Frame, qualitative sketch of influence line**



**Figure 2.4b. Live load pattern for negative moment at section A**

The influence line for negative moment at section A is shown in Figure 2.4a. Section A is defined as the intersection of the third beam from the bottom and the third column from the left, as shown in figure 2.4a. This is done by determining how the structure will respond to a unit discontinuity in slope section A. Given this influence line it is necessary to determine how to apply load in order to produce the worst possible effect. In this case it is clear that the positive areas of the influence line should receive the live load (see Figure 2.4b); loading the negative areas too would simply reduce the moment at section A. In general such loading patterns are referred to as ‘checkerboard’ loading patterns.

As more complex and multi-dimensional system are considered, the number of live load patterns increase enormously. In such circumstances analyzing the structure for all possible load patterns becomes an impossible task. However, various codes of practice have suggested a limited set of load patterns that an engineer may consider in predicting critical values of the design parameters.

From a practical point of view various codes of practices have suggested guidelines to find the critical load patterns for typical members of the structure. The American Concrete Institute (ACI)'s code requirements for Structural Concrete and Commentary while analyzing floor or roof member permits the load on a floor or roof member to be

- Limited to combinations of factored dead load on all spans with full factored live load on two adjacent spans.
- Limited to combinations of factored dead load on all spans with full factored live load on alternative spans.
- Live load to be applied only to the floor or roof under consideration, and the far ends of columns built integrally with the structure may be considered fixed.

In regard to the columns, ACI Code section 8.8 states:

- Columns shall be designed to resist the axial forces from factored loads on all floors or roof and the maximum moment from factored loads on a single adjacent span of the floor or roof under consideration. The loading condition giving the maximum ratio of moment to axial load shall also be considered.
- In frames or continuous construction, consideration shall be given to the effect of unbalanced floor or roof loads on both exterior and interior columns and of eccentric loading due to other causes.
- In computing moments in columns due to gravity loading, the far ends of columns built integrally with the structure may be considered fixed.
- The resistance to moments at any floor or roof level shall be provided by distributing the moment between columns immediately above and below the

given floor in proportion to the relative column stiffness and conditions of restraint.

The **Uniform Building Code** similarly states “the loading conditions which cause maximum shear force and bending moments along the member shall be investigated”.

It is important to note that for a 4 bay 40-story building, the total number of load patterns that must be considered is  $2^{160}$ , which is about  $1.5 \times 10^{48}$ . Such a calculation would be impossible even with the most extensive computational resources. Additionally, if an engineer relies on analysis based on fewer conventional load patterns, he may not be able to capture the critical scenario in the analysis and will be underestimating the response. The safety of structure in such cases may be potentially compromised.

Interval finite element analysis, on the other hand, guarantees that the critical scenario will be bounded in the sharp interval response. Before discussing formulation of interval finite element analysis, interval arithmetic needs to be reviewed. The next chapter focuses on various developments in the area of interval arithmetic, basic features of interval arithmetic and its application in engineering.

### 3. INTERVAL ARITHMETIC

Early use of interval representation is associated with the treatment of truncation errors in numerical calculations. For example, in a computational system with four decimal digits accuracy, the number 4.1231 would be represented as an interval [4.123, 4.124]. This approach allows the range of errors introduced by round-off errors to be precisely determined. Moore (1966), instead of computing a numerical approximation using limited-precision arithmetic, proceeded to construct intervals known in advance to contain the desired results. Several authors have bound rounding errors using intervals (Dwyer 1951; Sunaga 1958). However, Moore extended the use of interval analysis to bind the effects of errors from different sources, including approximation errors and errors in data.

Interval arithmetic was developed as an effective tool to obtain bounds on rounding and approximation errors. It is still to be seen how effective this tool can be when the range of the number is due to physical uncertainties instead of rounding errors.

A number of software libraries and extensions to programming language have been developed to implement interval calculations using computers (Blecher et al. 1987; Kullisch 1987). Additionally scientific calculators that are capable of dealing with interval arithmetic operations in addition to normal arithmetic have been developed very recently (GTREP at 2003).

Definitions of real intervals and operations with intervals can be found in a number of references (Hansen 1965; Moor 1966; Alefeld and Herzberger 1983; Neumaier 1990).

The fundamental concepts of interval arithmetic that has been seen in engineering applications (Mullen and Muhanna 1999) are covered here.

An interval number is a closed set in  $R$  that includes the possible range of an unknown real number, where  $R$  denotes the set of real numbers. A real interval is a set of the form

$$x \Leftrightarrow [x_l, x_u] := \{\tilde{x} \in R \mid x_l \leq \tilde{x} \leq x_u\}$$

Based on the above definitions, interval arithmetic is defined on sets of intervals, rather than on sets of real numbers. Interval mathematics can be considered a generalization of real numbers mathematics. Overestimation is a major drawback in interval computations. One reason is that only some of the algebraic laws, valid for real numbers, remain valid for intervals; other laws hold only in a weaker form (Neumaier 1990, pp. 19-21). There are two general rules for the algebraic properties of interval operations.

1. Two arithmetic expressions that are equivalent in real arithmetic, are equivalent in interval arithmetic when a variable occurs only once on each side. In this case, both sides yield the range of the expression. Consequently laws of commutativity, associativity, and neutral elements are valid in Interval Arithmetic.
2. If  $f$  and  $g$  are two arithmetical expressions that are equivalent in real arithmetic, then the inclusion  $f(x) \subseteq g(x)$  holds, if every variable occurs only once in  $f$ .

Also, a dependency problem arises when one or several variables occur more than once in an interval expression. Dependency may lead to catastrophic overestimation in interval computations. Precautions should be taken, if possible, to eliminate this effect.

Extending interval algebra in few more dimensions, it is easy to see that interval vectors and interval matrices exist in this generalized space. An interval vector is a vector whose components are interval numbers. An interval matrix is a matrix whose elements are

interval numbers. The interval matrix contains all the real matrices, whose elements are obtained from all possible values between the lower and upper bound of its interval elements. One important type of the matrix in mechanics is symmetric matrices. A symmetric interval matrix is one that contains only those real symmetric matrices whose elements are obtained from all possible values between lower and upper bound of its interval element. An interval vector is referred to as a box (Hansen 1992). The algebraic properties of interval matrix operations are provided by Neumaier (1990), Apostolatos and Kulisch (1968), and Mayer (1970).

Thus interval equations can be formed and solved for unknown interval variables. Such formulations and solution algorithms become very efficient tools for analyzing a structure if its relevant properties can be written as an interval. Subsequent chapters will introduce a specific formulation that will be used for interval finite element analysis for load combinations and load patterns. Since interval operations and equations require a different kind of treatment, specific computer codes need to be developed in order to solve large-scale problems.

In structural engineering interval arithmetic has already found various important applications. Uncertainties in mechanics were introduced as interval values by Muhanna and Mullen (2000). In such situations uncertain values were known to lie between two values and formulations were developed in order to solve a system of equations that involve interval quantities.

Although interval arithmetic was introduced by Moore (1966) and fuzzy sets theory by Zadeh (1965), the application of interval concepts to structural analysis is more recent. Koyluoglu, Cakmak and Nielson (1995) developed an interval approach utilizing the

finite-element method to deal with pattern loading and structural uncertainties. The solutions for the system of linear interval equations were obtained utilizing triangle inequalities and linear programming. The results were conservative bounds for the response quantities. Koyluoglu and Elishakoff (1998) introduced a comparison of stochastic and interval finite elements applied to shear frame exhibiting uncertain stiffness properties. Rao and Sawyer (1995), Rao and Berke (1997), and Rao and Chen (1998) developed different versions of an interval based finite element method to account for uncertainties in engineering problems. These publications were restricted to narrow intervals and approximate numerical results.

A significant effort has been devoted in the work of Rao and Chen (1998) to develop a new algorithm for the solution of linear interval equations. The developed algorithm used search-based operations with an accelerated step size and an attempt to find an optimum setting of unknown vector components.

Muhanna and Mullen (1995), Muhanna and Mullen (1996), Muhanna and Mullen (1999), and Mullen and Muhanna (1999) developed a finite element analysis procedure that utilizes the concept of fuzzy sets through interval calculations. They also computed the response of different structural systems due to geometric and loading uncertainties. Uncertainties were treated as possible values corresponding to a specific level of presumption ( $\alpha$ -cut). Results were exact in the case of load uncertainty and sharp for geometric uncertainty. Exact bounds on possible node displacements and forces were calculated by combinatorial calculations of all loading patterns, when computationally feasible. This formulation has been the basis for the current thesis work. In the next

section the above mentioned formulations of interval finite element analysis for interval loads will be presented.

## 4. INTERVAL FINITE ELEMENT ANALYSIS

Considering all the structural parameters as an interval number, a system of interval equations can be formulated in general as

$$k \cdot q = p \quad (1)$$

Or in the following explicit form:

$$\begin{bmatrix} [k_{11}^l, k_{11}^u] & [k_{12}^l, k_{12}^u] & \Lambda & [k_{1j}^l, k_{1j}^u] & \Lambda & [k_{1n}^l, k_{1n}^u] \\ [k_{21}^l, k_{21}^u] & [k_{22}^l, k_{22}^u] & \Lambda & [k_{2j}^l, k_{2j}^u] & \Lambda & [k_{2n}^l, k_{2n}^u] \\ \text{M} & \text{M} & \Lambda & \text{M} & \text{M} & \text{M} \\ [k_{i1}^l, k_{i1}^u] & [k_{i2}^l, k_{i2}^u] & \Lambda & [k_{ij}^l, k_{ij}^u] & \Lambda & [k_{in}^l, k_{in}^u] \\ \text{M} & \text{M} & \Lambda & \text{M} & \text{M} & \text{M} \\ [k_{n1}^l, k_{n1}^u] & [k_{n2}^l, k_{n2}^u] & \Lambda & [k_{nj}^l, k_{nj}^u] & \Lambda & [k_{nn}^l, k_{nn}^u] \end{bmatrix} \begin{bmatrix} [q_1^l, q_1^u] \\ [q_2^l, q_2^u] \\ \text{M} \\ [q_i^l, q_i^u] \\ \text{M} \\ [q_n^l, q_n^u] \end{bmatrix} = \begin{bmatrix} [p_1^l, p_1^u] \\ [p_2^l, p_2^u] \\ \text{M} \\ [p_i^l, p_i^u] \\ \text{M} \\ [p_n^l, p_n^u] \end{bmatrix} \quad (2)$$

For the case of interval loads, the stiffness matrix  $k$  is the conventional deterministic linear stiffness. The loading vector  $p$  will be interval quantity. The element generalized forces and the generalized displacements will be linear transformations of the interval quantities. In conventional finite-element formulations, the nodal load is given by

$$p = p_b + p_c \quad (3)$$

Where  $p_c$  = vector of concentrated load; and  $p_b$  = nodal load contribution from an element and has the form

$$p_b = \sum L^T \int N^T b(x) dx \quad (4)$$

Where  $L$  = Boolean connectivity matrix;  $b(x)$  = applied Traction; and  $N_i$  = shape function for node  $i$ . Also note that  $p_b$  itself can be broken in terms of element generalized nodal loads  $p_i$ .

$$p_i = \int N^T b(x) dx \quad (5)$$

While analyzing a structure for load patterns and load combinations, only the function  $b(x)$  (the magnitude of the load) is allowed to be an interval. To correctly evaluate inclusive interval values for  $p_i$ , attention must be paid to the sign of the terms  $N_i$ , as whenever  $N_i$  is positive, upper limit of interval need to be integrated however whenever  $N_i$  change sign to negative, the lower limit must be integrated.

As mentioned previously some of the conventional laws hold weakly in interval algebra, care has to be given to the order of multiplication as otherwise it will have a strong influence on the width of resulting intervals. One of the challenges that have to be faced in interval algebra will be controlling the width of the interval. One way to control width effectively will be delaying the use of interval values as much as possible.

It is important to see that some of the conventional characteristics of various analysis parameters still have to be satisfied. As an example, shape function  $N_i(x)$  if selected as a polynomial, automatically satisfies number of requirement of finite element for convergence, compatibility, rigid body motion and stability. Additionally it is practical to choose a loading function  $b(x)$  on element  $m$  in terms of an  $n^{\text{th}}$  order polynomial:

$$b(x) = \sum_{j=0}^{j=n} A_{mj} x^j \quad (6)$$

The element coefficient  $A_{mj}$  for each term of the polynomial  $n$  on element  $m$  can be written in matrix form as  $F_i$  with the dimension of  $(k \times 1)$ , where  $k$  is the number of polynomial coefficients.

$$F_i = \begin{pmatrix} A_{i0} \\ A_{i1} \\ M \\ An \end{pmatrix} \quad (7)$$

for  $i=1,2,\dots,m$ , where  $m$  = number of elements; for the whole system  $F$  can be expressed as

$$F = \begin{pmatrix} F_1 \\ F_2 \\ M \\ F_m \end{pmatrix} \quad (8)$$

Note that the dimension of  $F$  is  $[(m \times k) \times 1]$

The  $p_b$  vector now takes following form

$$p_b = MF \quad (9)$$

with the dimension of  $(ndof \times 1)$ , where  $ndof$  is number of degrees of freedom in the system, and where

$$M = [M_1 \quad M_2 \quad \Lambda \quad M_i \quad \Lambda \quad M_m] \quad (10)$$

with the dimension of  $[ndof \times (m \times k)]$ . The matrix  $M_i$  can be written as

$$M_i = [Q_i^0 \quad Q_i^1 \quad Q_i^2 \quad \Lambda \quad Q_i^n] \quad (11)$$

Note that the dimension of  $M_i$  is  $(ndof \times k)$ . The expression for  $Q_i$  may be given as

$$Q_i^j = L_i^T \int_{\Omega} N^T x^j dx \quad \forall i = 1, 2, 3 \Lambda m \quad (12)$$

And the dimension of  $Q_i$  is  $(ndof \times ndofel)$ .  $ndofel$  is element's number of degrees of freedom.

These expressions have both real and interval numbers embedded in them. As such all non-interval values are multiplied first and the last multiplication involves the interval

quantities. In this process, width of resulting interval is reduced to the minimum possible value.

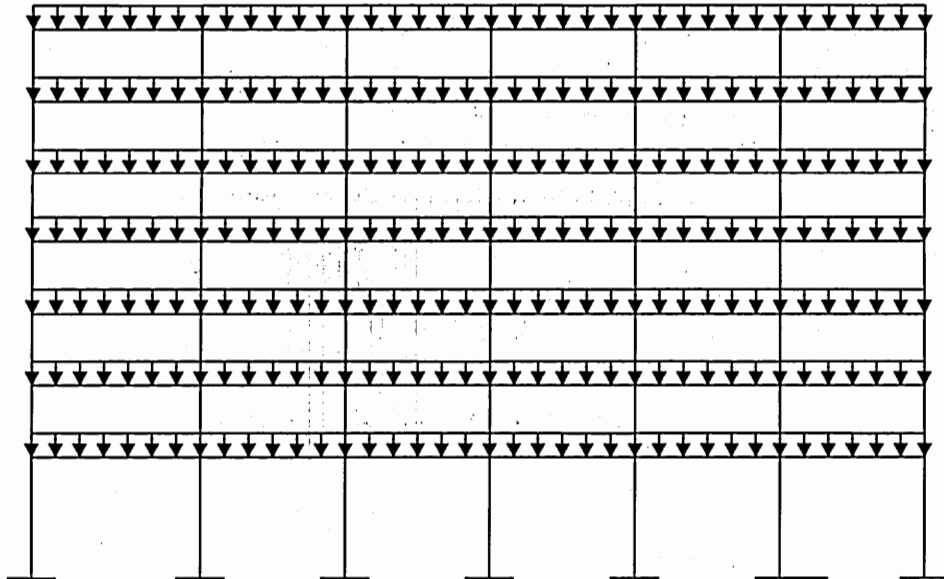
Since the formulation of interval finite analysis is already in place, the next step will be to see how uncertainty in the presence of live load can be handled using such formulation.

## 5. LOAD TYPES AND INTERVAL TREATMENT

In the current conventional load pattern analysis and interval finite element analysis, the following loads will be considered

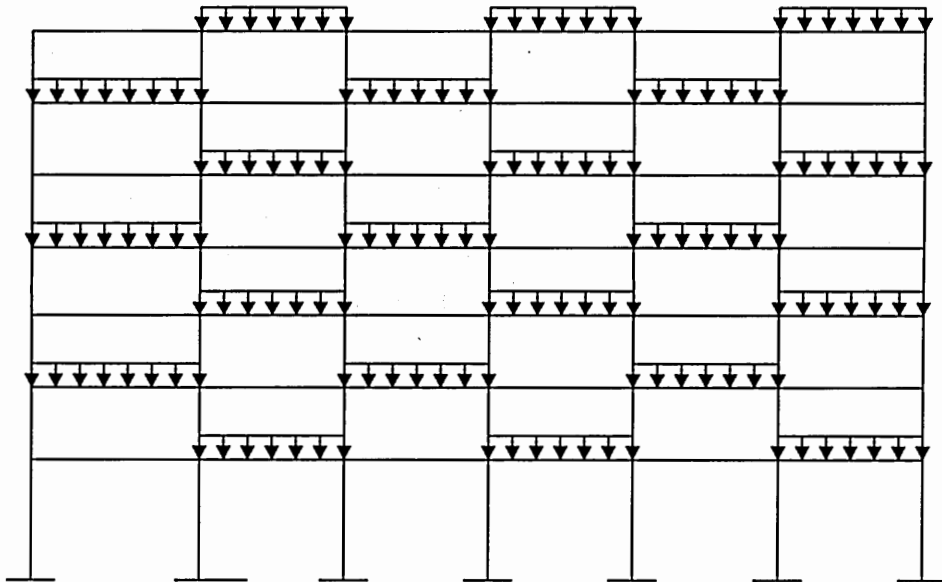
1. Dead Load
2. Live Load
3. Earthquake Load
4. Wind Load

The dead loads and live loads are being considered as uniformly distributed load. Figure 3.1 shows that all the beams will be loaded all the time as far as dead load is considered. Hence, in interval analysis the dead load will be taken as an interval load having lower and upper bound equal to the magnitude of uniformly distributed dead load.

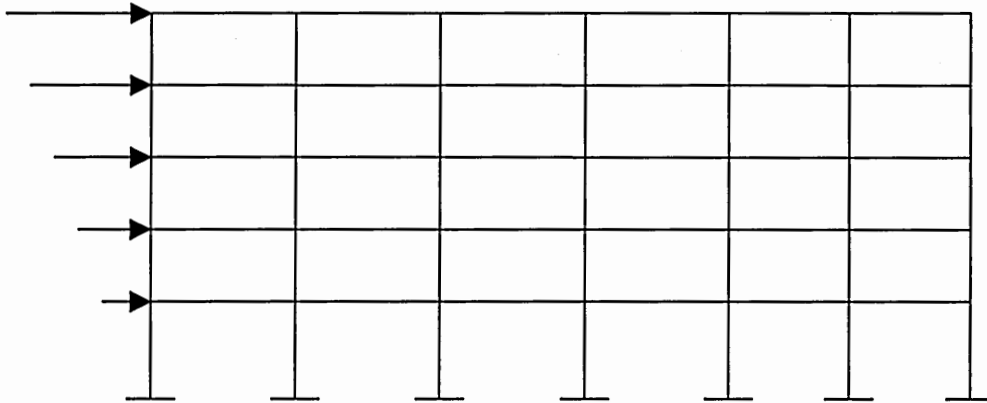


**Figure 3.1. Dead Load Presence on a Portal Frame**

For load patterns involving live loads, the absence of load on a given member can be treated as a load of magnitude equal to zero and the presence of load can be treated as a load of magnitude equal to its full value. Figure 3.2 indicates one of the live load patterns that an engineer might choose for conventional structural analysis. Even under this specific live load pattern, if required, uniformly distributed interval load can still be assigned to all the beams. As an example, all the beams that are not loaded will have a lower and upper bound of interval load equal to zero and the beams that are loaded will have a lower and upper bound of interval to the magnitude of live load. This kind of interval assignment will be needed for conventional load pattern analysis as the same program is used for conventional and interval FE analysis, and thus it requires entire load input to be interval quantities.



**Figure 3.2. Live load presence on a portal frame (checker-board pattern)**



**Figure 3.3. Earthquake/Wind Load (Static Equivalent) presence on a portal frame**

Figure 3.3 shows a typical earthquake and/or wind load acting on the frame structure. These loads are always present on the structure. Hence, such loads will be treated as deterministic loads in this work. In spite of their deterministic nature interval joint load can still be assigned, with lower and upper bound equal to magnitude of joint load acting on that joint. Such interval loads assignment will be needed as the program used to perform conventional or interval finite element analysis requires loads to be input as an interval.

As mentioned above, structure need to be analyzed for number of load combinations. However, if load factors in these load combinations are treated as interval quantities, such load combinations can be combined into one interval equation. In current thesis work, load combinations suggested by ASCE 2002 are being considered:

- 1.4 D
- 1.2 D + L
- 1.2 D + 1.6 L

- $1.2 D + 0.8 W$
- $1.2 D + 1.6 W + 1.0 L$
- $1.2 D + 1.0 E + 1.0 L$
- $0.9 D + 1.6 W$
- $0.9 D + 1.0 E$

It is easy to see that the load factor for dead load varies between 0.9 and 1.4, hence an interval  $\alpha$  with bounds between 0.9 and 1.4 can be assigned as interval load factor for dead load. Similarly some of the load combinations don't have any live load, however, some of the load combinations have load factor for live load as high as 1.6. In this way an interval load factor  $\beta$  i.e.  $[0, 1.6]$  can be assigned as an interval load factor for live load. Continuing in the same direction,  $\gamma$  and  $\delta$  can be defined as interval load factors for earthquake load and wind load respectively.

$$\alpha = [0.9, 1.4], \beta = [0, 1.6], \gamma = [0, 1] \text{ and } \delta = [0, 1.6]$$

Using these interval load factors, interval equation for ultimate load  $U$  can be written as

$$U = \alpha D + \beta L + \gamma EQ + \delta W \quad (13)$$

Equation 13 contains all the load combination in itself. Later, interval finite element analysis will be done for this interval equation and results in terms of the interval response will be presented.

In the next chapter a computer program that analyzes frame structures for conventional load pattern and interval FE analysis will be explored.

## 6. C++ PROGRAM AND A TEST RUN

A C++ program has been developed in order to carry out conventional structural analysis or interval finite element analysis for load patterns and load combinations. In this section, various features of the program will be explored and later some test runs will be presented in order to illustrate validity of the program.

This C++ program was initially written by Dr. Rafi Muhanna, Associate Professor at Georgia Institute of Technology, Atlanta, for carrying out interval finite element analysis under joint load and distributed load for frame element (See Appendix). The program was designed to take care of one set of joint loads, dead load and live load. The program accepts input load as deterministic and interval as well. The deterministic as well as the interval response for each of the three loading cases are being produced separately as the output file. To define response of the structure, bending moment, axial force and shear force at start node and end nodes, maximum span moment and its location within span and deflections of various joints are listed in the output file. This program was later been re-structured by Hao Zhang, PhD student at Georgia Institute of Technology, to make it efficient through the use of Object Oriented Programming.

The current analysis requires two types of joint loads (wind load and earthquake load) and load combinations. As such, the program has been further enhanced to accommodate two types of joint load and at the same time to accommodate load combinations involving dead load, live load, earthquake load and wind load. In addition, load factors can be entered as the interval quantities.

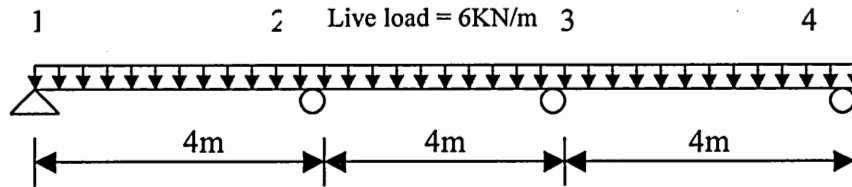
In its current form, the program is capable of computing span moment, end moment, shear force, axial force and deflection for various nodes or members for a given load combination. The load factors are given as interval input, so whenever lower and upper bound of the entire interval input is equal, the same program analyzes the structure for deterministic loads.

As a part of object oriented programming, the program has a frame class and its objects are created in main program. The frame class has been written in order to develop a typical "frame" data structure and it encapsulates essential characteristic of a real frame like number of nodes, number of members and various other parameters as protected variables. Public methods have been provided in order to perform any necessary operation like finding global stiffness matrix, incorporating boundary conditions, calculating element forces and joint displacements. In the main part of program, an object of frame is created and these public methods are called to perform interval finite element analysis.

A number of test cases have been run and tested against manual results in order to verify validity of this program, however only two such examples are being presented in this section.

**Example 1:**

The first example focuses on load pattern analysis of a three spans continuous beam under the application of live load (Figure 4.1a)



**Figure 4.1a. Finite Element consisting four nodes and three beam elements**

The following structural parameters are given input data:

Cross-sectional area of the beam =  $0.125 \text{ m}^2$

Moment of inertia of the beam =  $0.00260417 \text{ m}^4$

Modulus of elasticity =  $2 \times 10^6 \text{ KN/ m}^2$

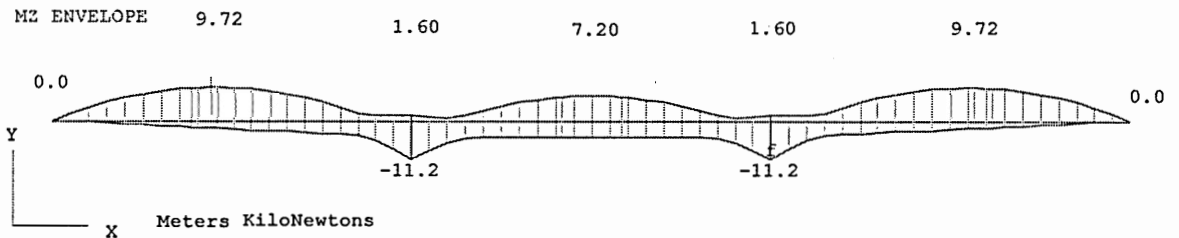
Live load =  $6 \text{ KN/m}$

Length of each of the three spans =  $4\text{m}$

Here the envelope for bending moments due to live load pattern is being considered throughout the beam. Maximum and minimum span moments and maximum and minimum end moments are only needed in order to draw such envelope. Traditionally, the engineer will be analyzing the structure under  $2^3$  (i.e. eight) live load patterns (including no loading case). Taking combinations of presence and absence of live load on every span, eight live load patterns can be generated. For this example, GTSTRUDL is used in order to analyze the beam for all eight load patterns. Figure 4.1b shows the direct output for the envelope of bending moments assembled from eight load patterns using GTSTRUDL.

Interval finite element analysis is capable of determining this envelope in one run. As stated in previous sections, absence and presence of live load on a span can be written as zero value and full value of live load occurring on that span, respectively. If the live load for every span is represented as an interval having bounds between zero and full value of

live load at that span, the interval live load on the structure will contain all the combinations of live load's presence and absence; and hence the interval response will capture all possible live load patterns in itself. So if an interval live load of  $[0, 6]$  KN/m is assigned to each of the three spans, this beam once solved for interval load quantity using finite element analysis, will give results accumulated from all the possible load patterns.



**Figure 4.1b. Moment envelope for all possible live load patterns (GTSTRUDL)**

**Table 1. Interval Finite Element Analysis results for three spans continuous beam**

	Interval span moment		
	Span 1	Span 2	Span 3
<i>Interval Finite Element Analysis</i>	$[-2.08, 9.707]$	$[-4.8, 7.2]$	$[-2.08, 9.707]$
	Interval end moment at start		
	Span 1	Span 2	Span 3
	$[0, 0]$	$[-1.6, 11.2]$	$[-1.6, 11.2]$
	Interval end moment at end		
	Span 1	Span 2	Span 3
	$[-11.2, 1.6]$	$[-11.2, 1.6]$	$[0, 0]$

It is important to note that interval maximum span moment bounds the results obtained from the eight load patterns. Table 1 gives the result from finite element analysis under the application of the interval load. It lists down interval response in terms of the interval span moment, interval end moment at start and end section of the beam. The lower and upper bounds of these interval end and span moments are in full agreement to the moments shown in corresponding values of moment envelope obtained from GTSTRUDL. However after the first decimal, slight difference between two results exists because of the fineness of the mesh used in GTSTRUDL.

**Example 2:**

In this example the steel frame shown in Figure 5 is being analyzed first for interval load application and later for various load combinations. The frame is under the application of three concentrated loads. It is assumed that any of these three concentrated loads may be present or absent at any time. This way these three joint loads lead to eight loading scenarios. By introducing the three loads as intervals with values between zero and maximum magnitude of the load, the entire eight-load scenario can be obtained in one interval run. Interval finite analysis performed with the interval form of concentrated loads captures all possible cases within the interval results. Here are the member properties for the various finite elements.

Beam properties:

1. Section: W21×57
2. Cross-sectional Area =  $16.7 \text{ in}^2 = 0.010774 \text{ m}^2$
3. Moment of Inertia =  $1170 \text{ in}^4 = 0.0004869 \text{ m}^4$

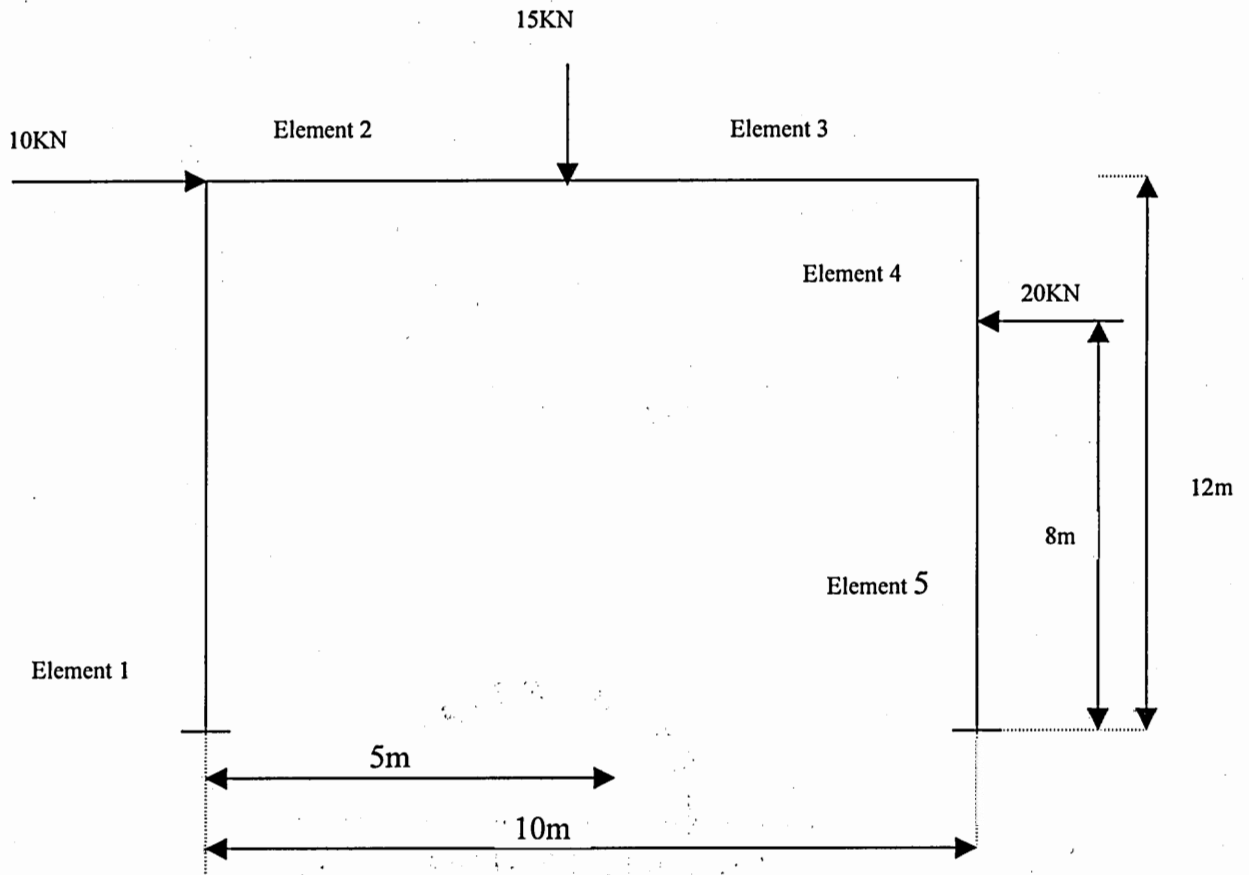
Column properties:

1. Section: W16×100
2. Cross-sectional Area =  $29.7 \text{ in}^2 = 0.01916 \text{ m}^2$
3. Moment of Inertia =  $1500 \text{ in}^4 = 0.0006243 \text{ m}^4$

Due to the presence of concentrated load within the span, the frame is broken into five finite elements.

Table 2 shows the results for axial force, shear force and moment at start and end nodes of all the five finite element of this frame from interval FE analysis. Further, the same frame has been analyzed for all the combination of presence and absence of each of the three joint loads leading to eight conventional structural analyses. These results when assembled to form an envelope give the maximum and minimum value of all the structural parameters.

Table 3 shows the minimum and maximum value of these parameters. It is important to note that table 2 and 3 are identical and it ensures the fact that interval finite element analysis is capable of accounting for all load scenarios in the interval response of the structure.



**Figure 5. Finite Element consisting five nodes and six-frame element**

**Table 2. Interval load input for interval finite element analysis**

<b>Node No.</b>	<b>Interval Force</b>		<b>Interval Moment</b>
	<b><math>F_x</math> (KN)</b>	<b><math>F_y</math> (KN)</b>	<b><math>M_z</math> (KN-m)</b>
<b>1</b>	[0, 0]	[0, 0]	[0, 0]
<b>2</b>	[0, 10]	[0, 0]	[0, 0]
<b>3</b>	[0, 0]	[-15, 0]	[0, 0]
<b>4</b>	[0, 0]	[0, 0]	[0, 0]
<b>5</b>	[-20, 0]	[0, 0]	[0, 0]
<b>6</b>	[0, 0]	[0, 0]	[0, 0]

**Table 3. Interval finite element analysis results for frame example (using C++ Program)**

<b>Element</b>	<b>1</b>	<b>2</b>	<b>3</b>	<b>4</b>	<b>5</b>
<b>F<sub>iX</sub> (KN)</b>	[-5.00487, 7.48309]	[0, 12.4782]	[0, 12.4782]	[0, 12.4782]	[-14.1157, 6.59393]
<b>F<sub>iY</sub> (KN)</b>	[-5.08176, 12.0171]	[-5.08176, 12.0171]	[-12.5818, 4.51712]	[-12.5818, 4.51712]	[-12.5818, 4.51712]
<b>M<sub>iZ</sub> (KN-m)</b>	[-48.7983, 34.6306]	[-25.4278, 40.9988]	[-24.7222, 5.61638]	[-16.9692, 38.1866]	[-40.5064, 11.8109]
<b>F<sub>jX</sub> (KN)</b>	[-7.48309, 5.00487]	[-12.4782, 0]	[-12.4782, 0]	[-12.4782, 0]	[-6.59393, 14.1157]
<b>F<sub>jY</sub> (KN)</b>	[-12.0171, 5.08176]	[-12.0171, 5.08176]	[-4.51712, 12.5818]	[-4.51712, 12.5818]	[-4.51712, 12.5818]
<b>M<sub>jZ</sub> (KN-m)</b>	[-40.9988, 25.4278]	[-5.61638, 24.7222]	[-38.1866, 16.9692]	[-11.8109, 40.5064]	[-72.4193, 40.9405]

Table 4. Conventional structural analysis results for frame example

Element	1		2		3		4		5	
	Min	Max	Min	Max	Min	Max	Min	Max	Min	Max
Conventional Analysis										
$F_x$ (KN)	-5.00487	7.48309	0	12.4782	0	12.4782	0	12.4782	-14.1157	6.59393
$F_y$ (KN)	-5.08176	12.0171	-5.08176	12.0171	-12.5818	4.51712	-12.5818	4.51712	-12.5818	4.51712
$M_{iz}$ (KN-m)	-48.7983	34.6306	-25.4278	40.9988	-24.7222	5.61638	-16.9692	38.1866	-40.5064	11.8109
$F_x$ (KN)	-7.48309	5.00487	-12.4782	0	-12.4782	0	-12.4782	0	-6.59393	14.1157
$F_y$ (KN)	-12.0171	5.08176	-12.0171	5.08176	-4.51712	12.5818	-4.51712	12.5818	-4.51712	12.5818
$M_{iz}$ (KN-m)	-40.9988	25.4278	-5.61638	24.7222	-38.1866	16.9692	-11.8109	40.5064	-72.4193	40.9405

## **7. INTERVAL ANALYSIS VS CONVENTIONAL ANALYSIS: LOAD COMBINATIONS & LOAD PATTERNS**

In this chapter a comparative study between conventional load pattern analysis and interval finite element analysis will be performed through the analysis of a portal frame for various load combinations and load patterns. A six-bay, seven-floor concrete frame structure has been chosen. The frame will be analyzed first for selected load patterns with specific load combinations; the response will be noted for selected members. Later, an interval value will be assigned to live load and the frame will be analyzed for the same load combinations, but this time under the application of interval load quantities using interval finite element analysis.

Since conventional analysis involves analyzing a structure through specific load patterns, various load patterns need to be considered. Ten load combinations are considered while analyzing a column; however, beam is being limited to only three load combinations as after study of several load combinations, not much deviation between two types of analysis is reported. Hence columns in particular are the major emphasis of this section. The analysis will cover several columns for axial force, shear force and maximum and minimum end moment. The results for the beam are being shown only in terms of maximum and minimum span moment. As there have been widely accepted load patterns for getting maximum and minimum span moment, only those particular patterns are being considered for beams. For columns, three different load patterns have been chosen for determining maximum positive and maximum negative end moment.

## 7.1 Formulation

The formulation of the problem will begin with identification of various structural parameters and important details of frame. In the next subsection, dead load, live load, wind load and earthquake load will be computed; only critical calculations are shown here.

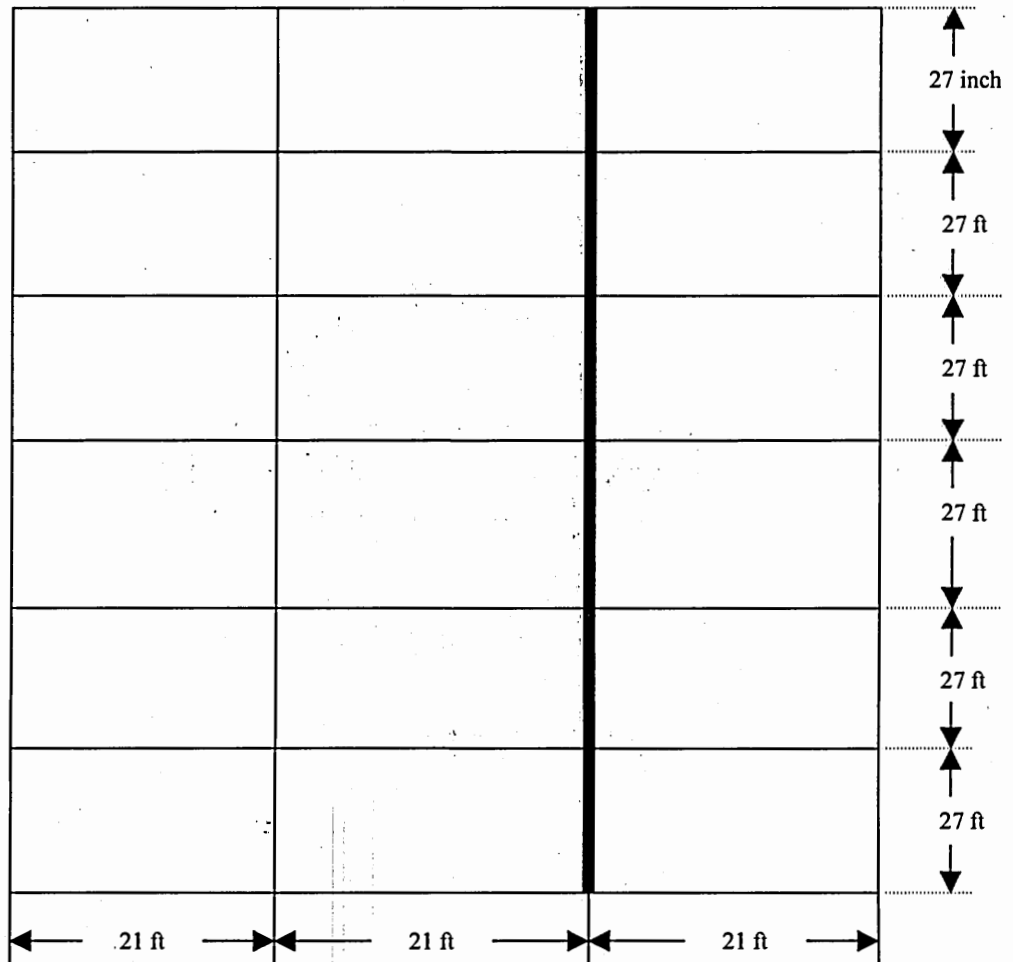
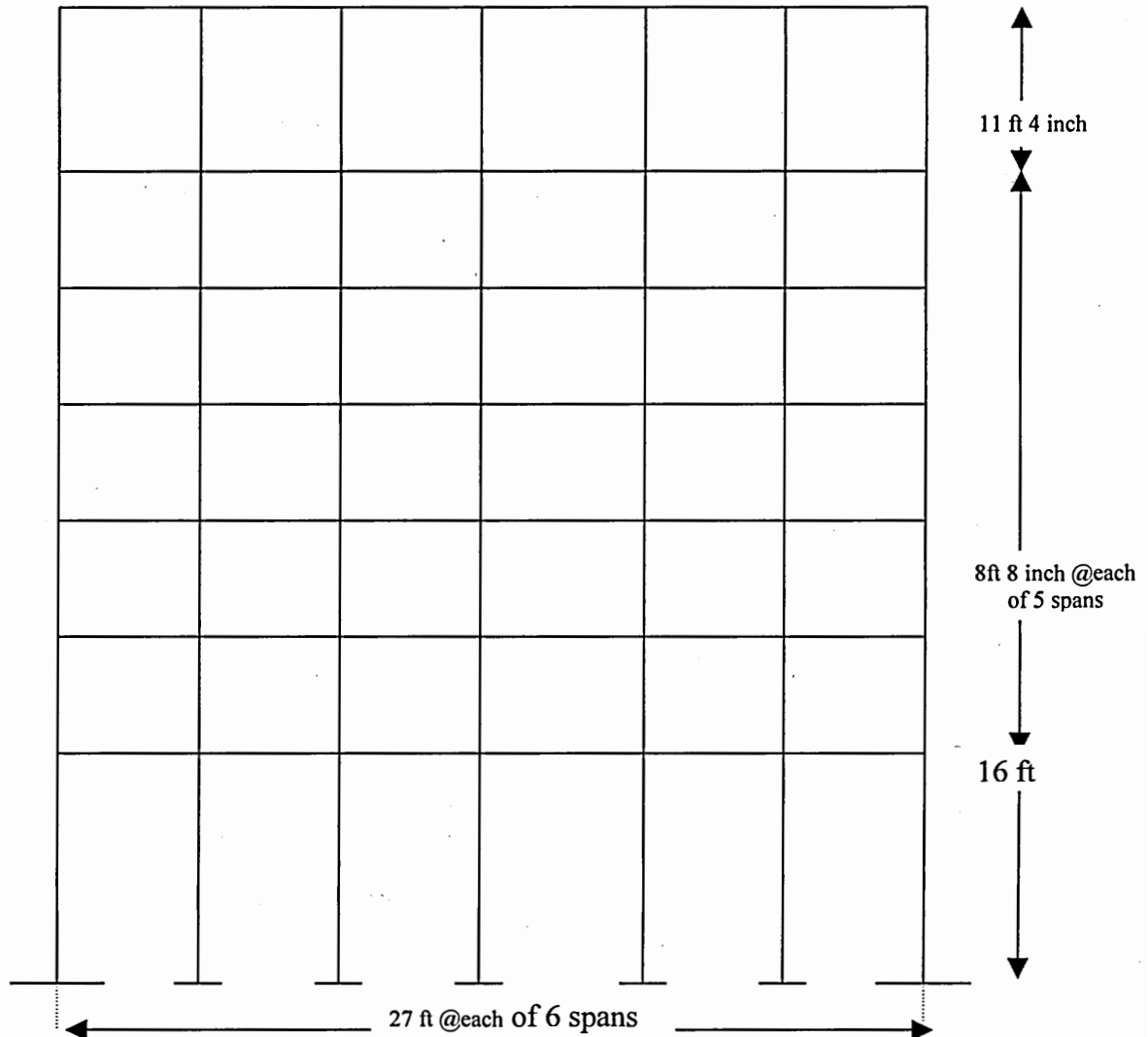


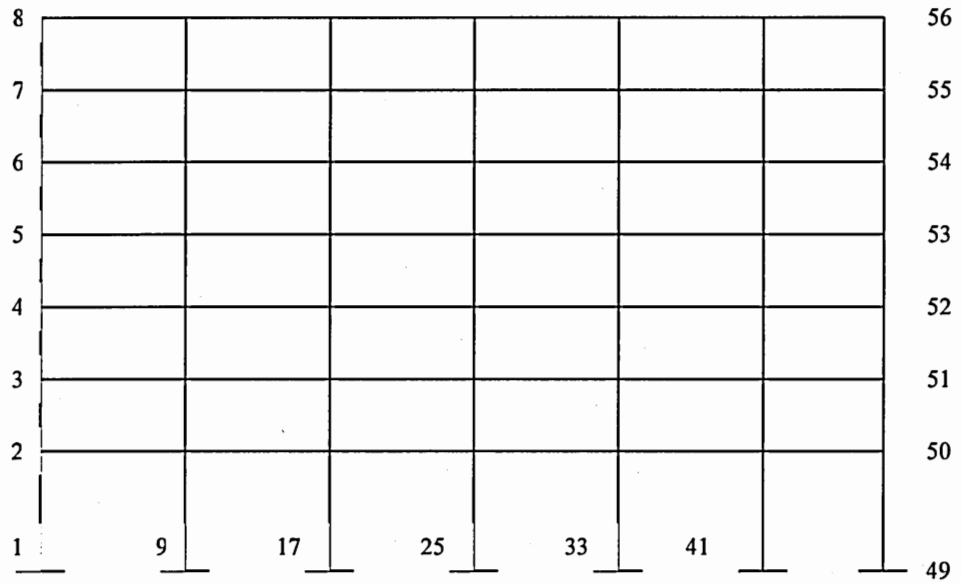
Figure 6.1. Typical floor plans

The last subsections of current chapters provide the significant analysis results for various finite elements. In the subsequent chapters these results will be assembled together in order to perform a comparative analysis.

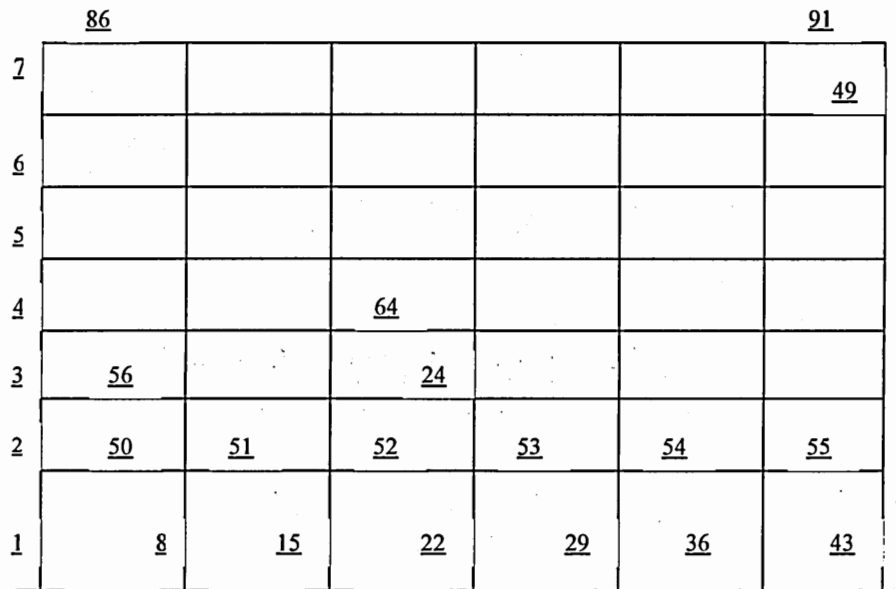


**Figure 6.2. Portal Frame in consideration (six bays & seven stories)**

Figure 6.1 shows the plan of the building. Figure 6.2 gives the elevation of a six bay seven-floor frame that is analyzed in subsequent subsection of this chapter. Joint numbering and member numbering is shown in Figure 6.3 and 6.4 respectively.



**Figure 6.3. Joints numbering for seven-floor frame**



**Figure 6.4. Frame elements numbering for seven-floor frame**

**7.1.1 Frame Data**

Six bay Seven Floor Concrete Hospital Building -RCC

Here are the various properties of the frame that may be of interest to the engineer. Since the real data is being used, units for this frame will also follow the actual data, which is an English standard.

1. Total Height = 70 ft 8 inch
2. Total span length = 162 ft
3. All beam are 24 inch by 18 inch
  1. Cross-sectional Area  $A = 432 \text{ inch}^2$
  2. Moment of Inertia  $I_{xx} = 20736 \text{ inch}^4$
4. All columns are 30 inch by 30 inch
  1. Cross-sectional Area  $A = 900 \text{ inch}^2$
  2. Moment of Inertia  $I_{xx} = 67500 \text{ inch}^4$
5. Modulus of elasticity for concrete is  $E_{\text{concrete}} = 3600 \text{ ksi}$

#### **7.1.2 Load Type/ Combinations:**

The following load types and load combinations are being considered in current interval finite element and conventional load pattern analysis.

1. Dead Load (D)
2. Live Load (L)
3. Earthquake Load (Static Equivalent) (EQ)
4. Wind load (W)
5. Load Combinations according to ASCE02
  - a. 1.4D
  - b. 1.2 D + 1.6 L
  - c. 1.2 D + L

- d.  $1.2 D + 0.8 W$
- e.  $1.2 D + 1.6 W + L$
- f.  $1.2 D \pm 1.0 E + L$
- g.  $0.9 D \pm 1.0 E$
- h.  $0.9 D + 1.6 W$

## 7.2 Load Computation

### 7.2.1 Dead Load and Live Load

Table 5 shows the location of building, seismic design category, type of frame, seismic use group and computed dead load and live load.

**Table 5. Dead load and live load for frame in consideration**

Location: Atlanta, GA
Seismic Design Category: C
Seismic Use Group: III
Seismic Force Resisting System: <i>Intermediate Reinforced Concrete Moment Frames</i>
Thickness of Slab $t = 10$ inch
Density of concrete $\rho = 0.15$ k/ft <sup>3</sup>
Dead Load $W_{DL} = 18.2$ k/ft
Live Load $W_{LL} = 18.0$ k/ft

### 7.2.2 Earthquake Load

Table 6(a) shows important information that is needed in order to evaluate earthquake load. Section 1615-1617 of IBC-16 is being used in order to evaluate earthquake load present on frame.

Table 6(b) shows contribution of every floor towards total statically equivalent joint load present on frame.

Table 7 has the final statically equivalent joint load for earthquake load existing on the five-story structure.

**Table 6a. Computation of earthquake load**

Weight of the Structure $W = 4000$ Kips
Design Spectral Response Acceleration at Short Period $S_{DS} = 0.1387$ g
Response Modification Factor $R = 4.5$
Importance Factor $I_E = 1.5$
Number of floors $N = 7$
Natural Time Periods $T = 0.1N = 0.7$ seconds
If $T < 0.5$ sec $\Rightarrow k = 1$ & If $T > 2.5$ sec $\Rightarrow k = 2$
Interpolating for values of k in between for $T = 0.7 \Rightarrow k = 1.1$

As per the “Equivalent Lateral Force Procedure” of the International Building Code, the static equivalent of the total earthquake load acting at structure is being given as

$$V = C_s \times W \quad (14)$$

Where  $C_s$  is being given as:

$$C_s = \frac{S_{DS}}{R/I_E} \quad (15)$$

And  $W$  is the weight of the structure.

For the structure being considered,  $C_s$  turns out to be 0.0831.

Vertical distribution of equivalent static earthquake force is given as

$$F_x = C_{VX} \times V \quad (16)$$

where  $V$  is the total design lateral force or shear. Note that the parameter  $C_{VX}$  accounts for the vertical distribution of equivalent static forces. The “Equivalent Lateral Force Procedure” gives the following expression in order to evaluate  $C_{VX}$ .

$$C_{VX} = \frac{w_x \times h_i^k}{\sum_{i=1}^N w_i \times h_i^k} \quad (17)$$

where  $h_i$  is the height from base to level  $i$  and  $N$  is the number of stories in frame.

Considering the symmetric nature of frame with respect to all floors, weight of the frame  $W$  is distributed equally among all floors.

If  $w_i$  is the weight corresponding to  $i^{\text{th}}$  floor and  $n$  are the total number of floors then

$$\Rightarrow w_i = W / n \forall i = 1 \dots n \quad (18)$$

**Table 6b. Computation of earthquake load (cont.)**

Story	Story Height	Story Height from Base $h_i$	$h_i^k$	$C_{VX}$
1	16	16	21.11	0.04
2	8.66	24.66	33.98	0.07
3	8.66	33.33	47.33	0.10
4	8.66	42	61.03	0.14
5	8.66	50.66	75.02	0.17
6	8.66	59.33	89.25	0.20
7	11.33	70.66	108.17	0.24
		Summation	435.92	

**Table 7. Earthquake loads as statically equivalent joint load**

Static Equivalent of Earthquake Load: $Q_E$	
$W = 4000$ Kips	
$C_s = 0.0831$	
$V = 332.4$ Kips	
Floor $i$	Joint Load At floor $i$ , $V_i$ (kips)
1	16.09
2	25.91
3	36.09
4	46.54
5	57.20
6	68.05
7	82.48

### 7.2.3 Wind Load

Section 6 of ASCE-7/2002 is used to develop appropriate static equivalent joint loads for wind load acting on the frame in consideration.

The minimum wind load = 10 lb/ft<sup>2</sup> is multiplied by the area of the building or structure projected on a vertical plane normal to the wind direction.

As per the Section 6.5.10 of ASCE-7/2002, velocity pressure,  $q_z$  evaluated at height  $z$  shall be calculated by the following equation:

$$q_z = 0.00256 \times K_z \times K_{zt} \times K_d \times V^2 \times I (\text{lb/ft}^2) \quad (19)$$

where

$K_z$  is the velocity pressure exposure coefficient.

$K_{zt}$  is the topographic factor.

$K_d$  is the wind directionality factor.

$V$  is the design wind speed.

And  $q_z$  is the velocity pressure at mean roof height  $z$ .

Design wind pressure on components and cladding for all buildings with  $h > 60$  ft shall be determined from the following equation:

$$p = (q \times G \times C_p - q_i \times G \times C_{pi})(lb/ft^2) \quad (20)$$

Where

$q = q_i = q_z$  is being calculated at windward or leeward walls at a height  $z$  above the ground.

$G$  is the gust factor and  $C_p$  &  $C_{pi}$  are external pressure coefficients.

Design wind loads for open buildings and other structures shall be determined by the following formula:

$$F = q_z \times G \times C_f \times A_f (lb) \quad (21)$$

Where

$q_z$  = velocity pressure evaluated at height  $z$  of the centroid of area  $A_f$  using the exposure defined in Section 6.5.6.3.2 of ASCE7-02.

$C_f$  = net force coefficients from tables 6-9 through 6-12 of ASCE7-02.

$A_f$  = projected area normal to the wind except where  $C_f$  is specified for the actual surface.

**Table 8a. Wind pressure calculations**

<b>Wind Pressure Calculations</b>
<b>Method 2: Analytical procedure from ASCE 7-98</b>
<b>Basic Wind Speed, V (mph) = 90</b>
<b>Exposure: A</b>
<b>Importance Factor, I = 1.15</b>
<b>Wind Directionality Factor, <math>K_d = 0.85</math></b>
<b><math>K_{zt} = 1</math></b>
<b><math>G_r = 0.85</math></b>
<b>For Exposure A, <math>\alpha = 5</math></b>
<b><math>Z_g</math> (ft.) = 1500</b>

**Table 8b. Wind pressure calculations (cont.)**

Calculate $K_z$ & $q_z$ for each height						
Floor	Level Height (ft)	Z (ft.)		$K_z$	$q_z$ (lbs/ft <sup>2</sup> )	
Foundation	0	0		0.680	16.22	
1	16	16		0.680	16.22	
2	8.66	24.66		0.680	16.22	
3	8.66	33.33		0.680	16.22	
4	8.66	42		0.680	16.22	
5	8.66	50.67		0.680	16.22	
6	8.66	59.33		0.680	16.22	
Roof	11.33	70.67		0.680	16.22	
		L/B	Cp	L/B	Cp	
		2	-0.3			
L (ft)	162	2.57	X			
B (ft)	63	4	-0.2	Cp	-0.27	

Tables 8 (a), 8 (b) and 8 (c) give the calculations done in order to obtain the statically equivalent joint loads for wind loads present on a seven-story frame. Table 9 contains the final wind load present on the frame in consideration.

**Table 8c. Wind pressure calculations (cont.)**

Calculate the wind pressure from the two directions				
Wind From Ends $p_z$ (psf)				
Z (ft.)	Windward End	Leeward End	Sides	Total $p_z$ (psf)
L/B = 2.57	$C_p = 0.8$	$C_p = -0.271$	$C_p = -0.7$	
0	11.03	-3.74	-9.65	14.77
16	11.03	-3.74	-9.65	14.77
24.66667	11.03	-3.74	-9.65	14.77
33.33333	11.03	-3.74	-9.65	14.77
42	11.03	-3.74	-9.65	14.77
50.67	11.03	-3.74	-9.65	14.77
59.33	11.03	-3.74	-9.65	14.77
70.67	11.03	-3.74	-9.65	14.77

**Table 9. Static equivalent of wind load**

Calculate the static equivalent of wind pressure		
Effective Width	21	
Height	Pressure	Design Wind Load
Ft	Psf	Kips
0	14.77	
16	14.77	4.96
24.66	14.77	2.68
33.33	14.77	2.68
42	14.77	2.68
50.67	14.77	2.68
59.33	14.77	2.68
70.67	14.77	3.51

Table 10 summarizes earthquake load and wind load as statically equivalent joint load occurring on various joints.

**Table 10. Summary of loads**

<b>Summary of Loads</b>			
<b>Dead Load</b>	U.D.L at all beam = 18.2 kips/Ft		
<b>Live Load</b>	U.D.L at all beam = 18 kips/ft		
<i>Earthquake Load</i>	Joint Load		
<i>Wind Load</i>	Joint Load		
<i>Joint</i>	<i>Height (ft)</i>	<b>Earthquake Load (kips)</b>	<b>Wind Load (kips)</b>
2	16	16.1	4.96
3	24.66	26	2.68
4	33.33	36.1	2.68
5	42	46.6	2.68
6	50.67	57.2	2.68
7	59.33	68.1	2.68
8	70.67	82.5	3.51

**Remarks:**

As per the section 1617.1 of IBC-16, the seismic load effect  $E$  for use in above specified load combinations, shall be determined as follows:

$$E = \rho \times Q_E + 0.2S_{DS} \times D \quad (22)$$

Where:

$D$  = the effect of dead load

$E$  = the combined effect of horizontal and vertical earthquake-induced forces

Factor  $\rho$  = a reliability factor based on system

$Q_E$  = the effects of horizontal seismic forces

$S_{DS}$  = the design spectral response acceleration at short periods

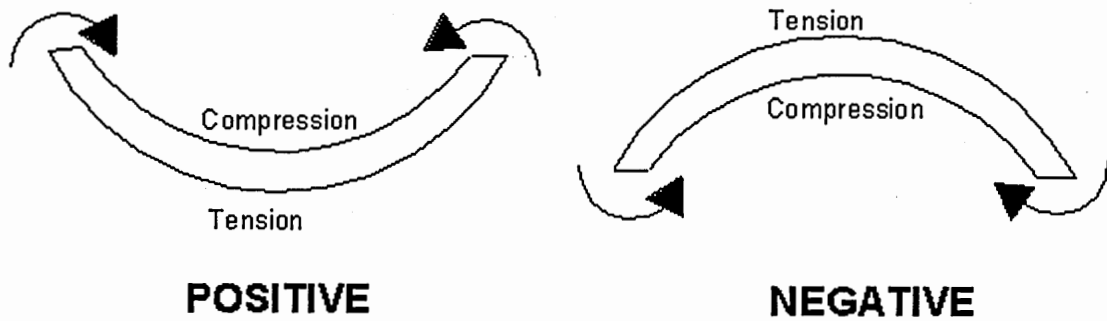
For the seismic design category  $C$ ,  $\rho = 1$

For the site and soil in consideration,  $S_{DS} = 0.1387$ . This implies that expression for  $E$  turn out to be

$$E = Q_E + 0.02774 \times D \quad (23)$$

Note that,  $E$  once included in the expressions of load combination, will modify the load factors of Dead Load and Horizontal Seismic Loads as computed above.

**Sign Convention:**



**Figure 7.0. Sign convention for positive and negative bending moment**

## 7.3 Comparative Analysis for Load Patterns & Load Combinations

### 7.3.1 Case 1-Maximum Span Moment in a beam

In this case the maximum span moment in beam 64 (figure 7.1) is the current design parameter. Using the general principle of influence the structure may be analyzed for this particular live load pattern in association with a number of load combinations:

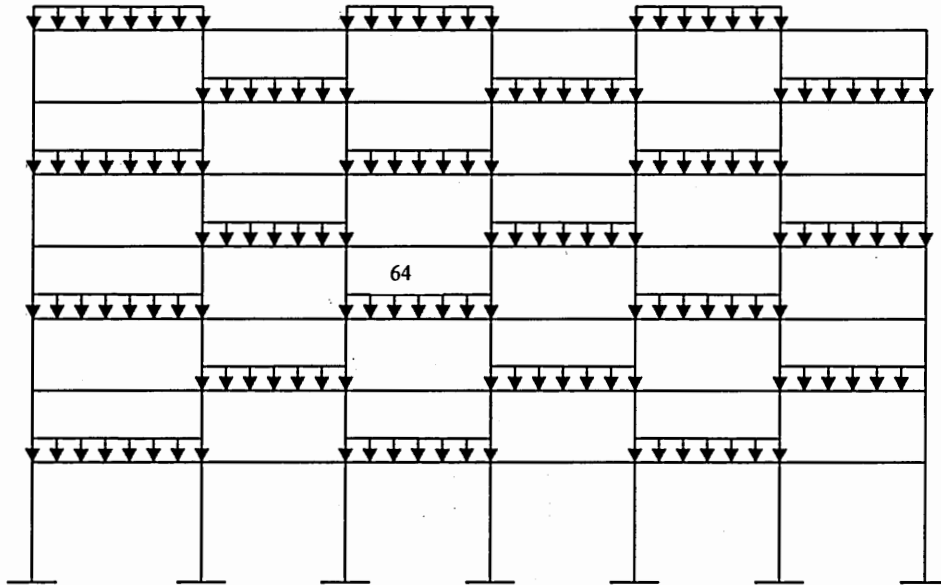


Figure 7.1. Case 1: Live load pattern for maximum span moments in beam

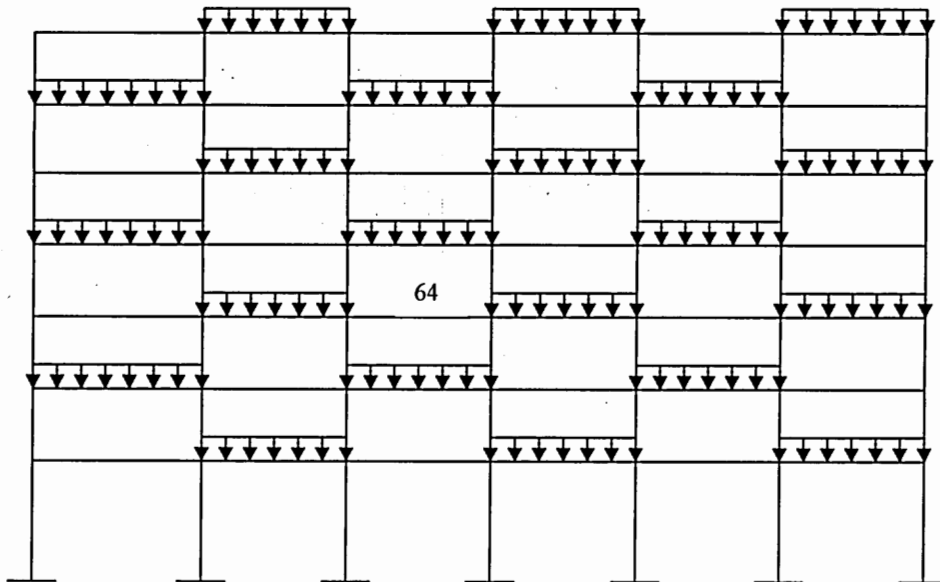
Table 11. Maximum Span Moment in beam

Beam 64	Interval Analysis	Conventional Analysis
Load Combination	Interval Span Moment (kips-inch)	Maximum Span Moment (kips-inch)
1.4D	[9295, 9295]	9295
1.2D+1.6L	[7016,19420]	19410
1.2D+L	[7373,15130]	15120

Maximum span moments obtained from conventional load patterns are within the interval span moment calculated using interval FE analysis (Table 11). This shows enclosure of conventional result in the interval FE analysis result. It is important to note that not only this particular load pattern is bounded by the enclosure, but every load as well. Span moment is chosen as one of the representative parameters in this case. One more parameter, end moment, will also be considered in a subsequent section. However, deflection at any point, shear force and axial force are all equally valid parameters that can be chosen to demonstrate this kind of concept.

### 7.3.2 Case 2-Minimum Span Moment in a beam

In this case the minimum moment at the starting node of beam 64 (figure 7.2) is the current design parameter. Using the general principle of influence lines structure may be analyzed for this particular live load pattern in association with a number of load combinations:



**Figure 7.2. Case 2: Live load pattern for minimum span moment in beam**

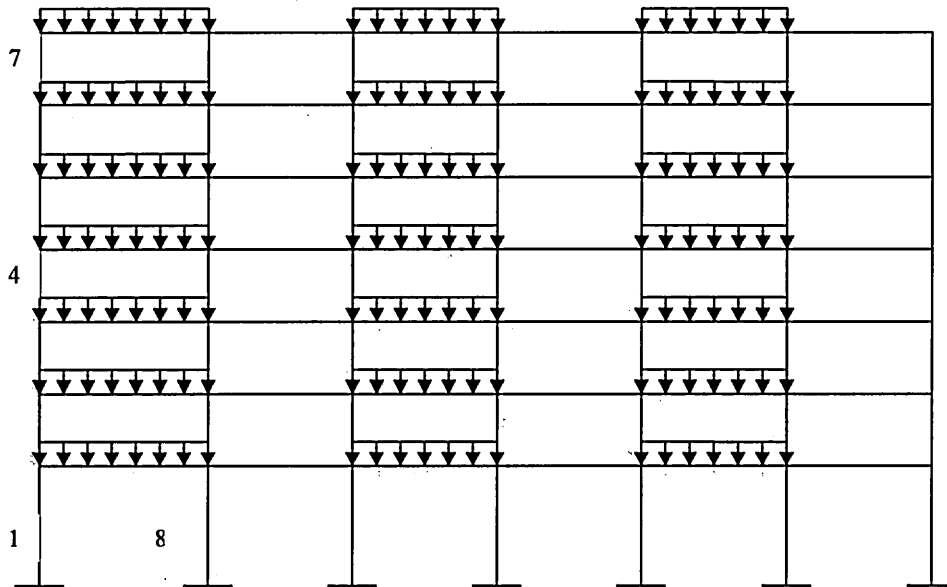
**Table 12. Minimum Span Moment in beam**

<b>Beam 64</b>	<b>Interval Analysis</b>	<b>Conventional Analysis</b>
<b>Load Combination</b>	<b>Interval Span Moment (kips-inch)</b>	<b>Minimum Span Moment (kips-inch)</b>
<b>1.4D</b>	[9295, 9295]	9295
<b>1.2D+1.6L</b>	[7016, 19420]	7028
<b>1.2D+L</b>	[7373, 15130]	7380

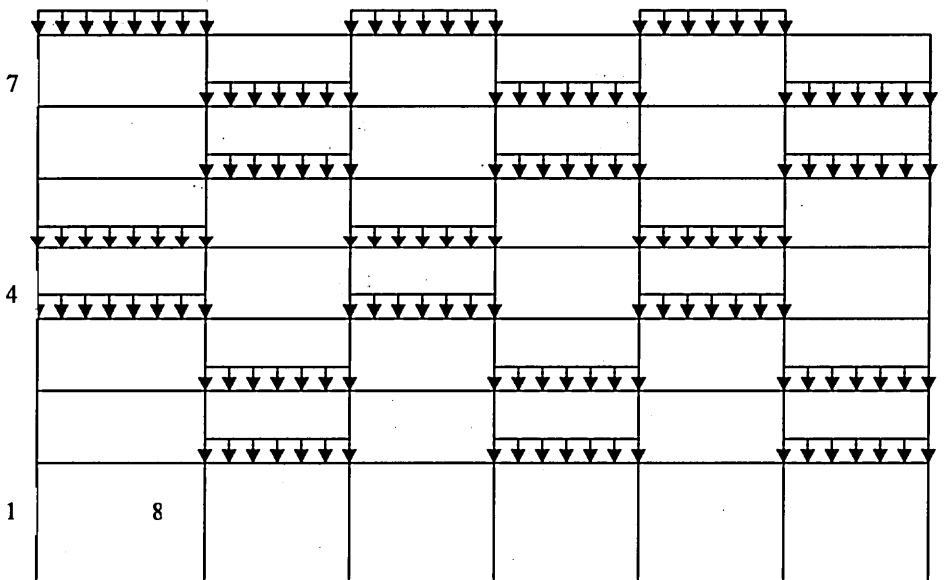
Once again, enclosure of the results from the load pattern chosen for minimum span moment in a beam, within the results from Interval FE Analysis, can be seen. The results in table 12 indicate that the minimum span moment obtained from live load pattern is within the interval value of span moment computed using interval finite element analysis. In these cases only three load combinations have been considered, but in the next section column is analyzed for 10 load combinations to show the general tendency of getting enclosure within interval FE results.

### **7.3.3 Case 3- Maximum/Minimum End Moments in a Column**

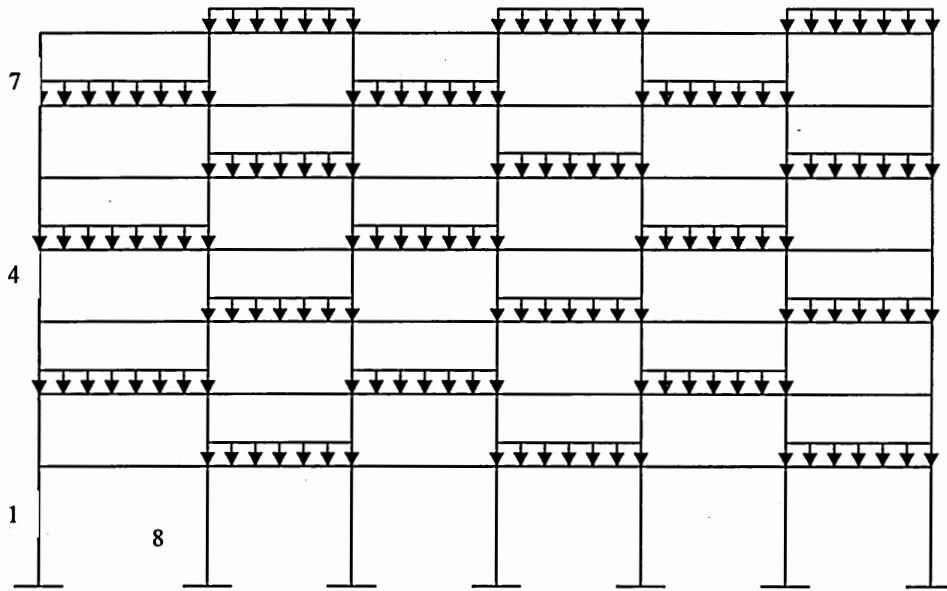
In this case maximum end moment of a column is the current design parameter. End moments for column 1, 4, 7 and 8 will be presented. Using general principle of influence lines structure may be analyzed for some definite live load pattern in association with number of load combinations. Here are three widely used load patterns that will be considered for maximum and minimum end moment in the column:



**Figure 7.3. Case 3: Live load pattern A for maximum/minimum end moment in a column**



**Figure 7.4. Case 3: Live load pattern B for maximum/minimum end moment in a column**



**Figure 7.5. Case 3: Live load pattern C for maximum/minimum end moment in a column**

**Table 13 End Moment in column element 8 as an effect of Live Load pattern A, B and C**

<b>Column 8</b>	<b>Interval Analysis</b>	<b>Conventional Analysis</b>	<b>Conventional Analysis</b>	<b>Conventional Analysis</b>
<b>Load Combination</b>	<b>Interval End Moment (kips-inch)</b>	<b>End Moments (kips-inch) Load Pattern "A"</b>	<b>End Moments (kips-inch) Load Pattern "B"</b>	<b>End Moments (kips-inch) Load Pattern "C"</b>
<b>1.4D</b>	[-1293, -1293]	-1293	-1293	-1293
<b>1.2D+1.6L</b>	[-12193.5, 8515.77]	4927.87	-8307.41	-11568.9
<b>1.2D+L</b>	[-8036.55, 4906.75]	2664.31	-5607.74	-7646.14
<b>1.2D+0.8W</b>	[-955.202, -955.202]	-955.202	-955.202	-955.202
<b>1.2 D + 1.6 W + L</b>	[-7730.38, 5212.92]	2970.49	-5301.56	-7339.97
<b>1.2 D + 1.0 E<sub>1</sub> + L</b>	[-5591.51, 7351.79]	5109.36	-3162.69	-5201.09
<b>1.2 D + 1.0 E<sub>2</sub> + L</b>	[-5563.06, 7380.24]	5137.8	-3134.25	-5172.65
<b>0.9 D + 1.0 E<sub>1</sub></b>	[1590.55, 1590.55]	1590.55	1590.55	1590.55
<b>0.9 D + 1.0 E<sub>2</sub></b>	[1642.27, 1642.27]	1642.27	1642.27	1642.27
<b>0.9 D + 1.6 W</b>	[-525.043, -525.043]	-525.043	-525.043	
<b>load factors as Interval</b>	[-15419.8, 14588.3]			

Figure 7.3, 7.4 and 7.5 shows the live load pattern A, B and C respectively, used in order to calculate end moment in various columns. Table 13 focuses on column element 8 and gives the interval end moment obtained from Interval Finite Element Analysis and end moments from load pattern A, B and C respectively. The last row of the table 13 shows the interval end moment at the end of column 8 as per the interval load factors. In this

particular case, all the load combinations have been combined into one interval equation and interval finite element analysis is done under one interval load combination equation. The interval end moments obtained in this way contain all the interval end moments that are obtained from specific load combination.

**Table 14. Axial Force in column 8 as an effect of Live Load pattern A, B and C**

Column 8	Interval Analysis	Conventional Analysis	Conventional Analysis	Conventional Analysis
<i>Load Combination</i>	Interval Axial force (kips)	Axial Force (kips) Load Pattern “A”	Axial Force (kips) Load Pattern “B”	Axial Force (kips) Load Pattern “C”
<b>1.4D</b>	[4798.24, 4798.24]	4798.24	4798.24	4798.24
<b>1.2D+1.6L</b>	[4110.8, 9537]	6837.8	6821.76	6826.16
<b>1.2D+L</b>	[4111.54, 7502.92]	5815.91	5805.89	5808.64
<b>1.2D+0.8W</b>	[4112.82, 4112.82]	4112.82	4112.82	4112.82
<b>1.2 D + 1.6 W + L</b>	[4111.64, 7503.01]	5816.01	5805.98	5808.74
<b>1.2 D + 1.0 E<sub>1</sub> + L</b>	[4123.01, 7514.38]	5827.38	5817.36	5820.11
<b>1.2 D + 1.0 E<sub>2</sub> + L</b>	[4017.45, 7408.82]	5721.82	5711.8	5714.55
<b>0.9 D + 1.0 E<sub>1</sub></b>	[3182.42, 3182.42]	3182.42	3182.42	3182.42
<b>0.9 D + 1.0 E<sub>2</sub></b>	[2990.49, 2990.49]	2990.49	2990.49	2990.49
<b>0.9 D + 1.6 W</b>	[3084.68, 3084.68]	3084.68	3084.68	3084.68
<b>Load factors as Interval</b>	[3081.83, 10225.2]			

The interval axial forces obtained from interval finite element analysis and axial force from load pattern A, B and C respectively for column element 8 are given in table 14. It is important to note that as shown for interval span moment, the interval response for

axial force again bounds conventional results. The last row of Table 14 and Table 15 show the interval axial force and interval shear force when load factors are taken as interval. Interval shear force obtained from interval load factor equation, bounds all the interval shear force that is obtained using finite element analysis for a given load combination. Note that load pattern A results in the maximum axial force in column 8 for all the load combinations; this is the same load pattern that resulted in the maximum positive end moment in the same column (Table 13 and 14). Table 13 shows that the maximum negative moment for the column in consideration occurs due to load pattern C. However, this load pattern does not yield the maximum axial force. The three load patterns used here are the most popular ones, do not necessarily give the critical scenario; however, interval results will always capture critical response of the structure.

Table 15 indicates how different shear force values obtained from load pattern A, B and C are contained within the interval shear force calculated using interval finite element analysis. Table 13, Table 14 and Table 15 clearly show that the end moments, axial force and shear force in column 8 obtained from specific live load patterns are non-conservative.

Additionally similar results are presented for few selected columns present at 1<sup>st</sup>, 4<sup>th</sup> and 7<sup>th</sup> floor. Columns 1, 4 and 7 have been chosen from these floors. For each of the load combinations, table 16 gives interval end moments and end moments in column 1 obtained from three live load pattern. Table 17 and Table 18 provide the similar results for axial force and shear force in column 1. Table 19, 20 and 21 present a comparison of interval response in terms of the end moment, axial force and shear force in column 4

with corresponding conventional load pattern analysis results. Similar results are presented for column 7 in Table 22, Table 23 and Table 24.

**Table 15. Shear Force in column 8 as an effect of Live Load pattern A, B and C**

Column 8	Interval Analysis	Conventional Analysis	Conventional Analysis	Conventional Analysis
<i>Load Combination</i>	Interval Shear force (kips)	Shear Force (kips) Load Pattern A	Shear Force (kips) Load Pattern B	Shear Force (kips) Load Pattern C
<b>1.4D</b>	[13.2359, 13.2359]	13.2359	13.2359	13.2359
<b>1.2D+1.6L</b>	[-63.0328, 100.68]	-35.014	71.1735	94.8429
<b>1.2D+L</b>	[-35.1411, 67.1795]	-17.6294	48.7378	63.5312
<b>1.2D+0.8W</b>	[8.59973, 8.59973]	8.59973	-8.59973	8.59973
<b>1.2 D + 1.6 W + L</b>	[-40.6318, 61.6888]	-23.12	43.2472	58.0406
<b>1.2 D + 1.0 E<sub>1</sub> + L</b>	[-85.0459, 17.2747]	-67.5342	-1.16695	13.6264
<b>1.2 D + 1.0 E<sub>2</sub> + L</b>	[-85.3371, 16.9835]	-67.8254	-1.45814	13.3353
<b>0.9 D + 1.0 E<sub>1</sub></b>	[-41.1578, -41.1578]	-41.1578	-41.1578	-41.1578
<b>0.9 D + 1.0 E<sub>2</sub></b>	[-41.6872, -41.6872]	-41.6872	-41.6872	-41.6872
<b>0.9 D + 1.6 W</b>	[3.01813, 3.01813]	3.01813	3.01813	3.01813
<b>Load factors as Interval</b>	[-144.797, 126.077]			

**Table 16. End Moment in column 1 as an effect of Live Load A, B and C**

<b>Column 1</b>	<b>Interval Analysis</b>	<b>Conventional Analysis</b>	<b>Conventional Analysis</b>	<b>Conventional Analysis</b>
<i>Load Combination</i>	<b>Interval End Moment (kips-inch)</b>	<b>End Moments (Kips-inch) Load Pattern A</b>	<b>End Moments (Kips-inch) Load Pattern B</b>	<b>End Moments (Kips-inch) Load Pattern C</b>
<b>1.4D</b>	[-8097.51, -8097.51]	-8097.51	-8097.51	-8097.51
<b>1.2D+1.6L</b>	[-17727.6, -5304.45]	-15045.4	-7840.98	-6373.14
<b>1.2D+L</b>	[-13682.5, -5918.05]	-12006.1	-7503.38	-6332.37
<b>1.2D+0.8W</b>	[-6813.91, -6813.91]	-6813.91	-6813.91	-6813.91
<b>1.2 D + 1.6 W + L</b>	[-13428.9, -5664.43]	-11752.5	-7249.77	-6332.37
<b>1.2 D + 1.0 E<sub>1</sub> + L</b>	[-12164.6, -4400.18]	-10488.2	-5985.51	-5068.11
<b>1.2 D + 1.0 E<sub>2</sub> + L</b>	[-11986.5, -4222.03]	-10310.1	-5807.36	-4889.96
<b>0.9 D + 1.0 E<sub>1</sub></b>	[-3833.42, -3833.42]	-3833.42	-3833.42	-3833.42
<b>0.9 D + 1.0 E<sub>2</sub></b>	[-3509.52, -3509.52]	-3509.52	-3509.52	-3509.52
<b>0.9 D + 1.6 W</b>	[-4951.92, -4951.92]	-4951.92	-4951.92	-4951.92
<b>Load factors as Interval</b>	[-19401.5, -1264.45]			

**Table 17. Axial Force in column 1 as an effect of Live Load pattern A, B and C**

<b>Column 1</b>	<b>Interval Analysis</b>	<b>Conventional Analysis</b>	<b>Conventional Analysis</b>	<b>Conventional Analysis</b>
<b>Load Combination</b>	<b>Interval Axial force (kips)</b>	<b>Axial Force (kips) Load Pattern A</b>	<b>Axial Force (kips) Load Pattern B</b>	<b>Axial Force (kips) Load Pattern C</b>
<b>1.4D</b>	[2420.95, 2420.95]	2420.95	2420.95	2420.95
<b>1.2D+1.6L</b>	[2063.23, 4822.78]	4794.58	3249.73	3246.95
<b>1.2D+L</b>	[2067.68, 3792.4]	3774.77	2809.24	2801.13
<b>1.2D+0.8W</b>	[2071.92, 2071.92]	2071.92	2071.92	2071.92
<b>1.2 D + 1.6 W + L</b>	[2061.31, 3786.02]	3768.4	2802.87	2801.13
<b>1.2 D + 1.0 E<sub>1</sub> + L</b>	[1991.28, 3716]	3698.37	2732.84	2731.11
<b>1.2 D + 1.0 E<sub>2</sub> + L</b>	[1938.02, 3662.74]	3645.11	2679.58	2677.85
<b>0.9 D + 1.0 E<sub>1</sub></b>	[1523.51, 1523.51]	1523.51	1523.51	1523.51
<b>0.9 D + 1.0 E<sub>2</sub></b>	[1426.67, 1426.67]	1426.67	1426.67	1426.67
<b>0.9 D + 1.6 W</b>	[1549.95, 1549.95]	1549.95	1549.95	1549.95
<b>Load factors as Interval</b>	[1453.08, 5172.38]			

**Table 18. Shear Force in column 1 as an effect of Live Load pattern A, B and C**

<b>Column 1</b>	<b>Interval Analysis</b>	<b>Conventional Analysis</b>	<b>Conventional Analysis</b>	<b>Conventional Analysis</b>
<i>Load Combination</i>	<b>Interval Shear force (kips)</b>	<b>Shear Force (kips) Load Pattern A</b>	<b>Shear Force (kips) Load Pattern B</b>	<b>Shear Force (kips) Load Pattern C</b>
<b>1.4D</b>	[68.7488, 68.7488]	68.7488	68.7488	68.7488
<b>1.2D+1.6L</b>	[48.8848, 146.66]	126.165	68.7097	58.4322
<b>1.2D+L</b>	[52.6509, 113.76]	100.951	65.0414	53.4437
<b>1.2D+0.8W</b>	[56.3404, 56.3404]	56.3404	56.3404	56.3404
<b>1.2 D + 1.6 W + L</b>	[47.4766, 108.586]	95.7765	59.8672	53.4437
<b>1.2 D + 1.0 E<sub>1</sub> + L</b>	[9.97928, 71.0887]	58.2792	22.3698	15.9464
<b>1.2 D + 1.0 E<sub>2</sub> + L</b>	[8.4668, 69.5762]	56.7667	20.8574	14.4339
<b>0.9 D + 1.0 E<sub>1</sub></b>	[2.76157, 2.76157]	2.76157	2.76157	2.76157
<b>0.9 D + 1.0 E<sub>2</sub></b>	[0.0116125, 0.0116125]	0.0116125	0.0116125	0.0116125
<b>0.9 D + 1.6 W</b>	[39.0214, 39.0214]	39.0214	39.0214	39.0214
<b>Load factors as Interval</b>	[-17.0043, 159.655]			

**Table 19. End Moment in column element 4 as an effect of Live Load pattern A, B and C**

<b>Column 4</b>	<b>Interval Analysis</b>	<b>Conventional Analysis</b>	<b>Conventional Analysis</b>	<b>Conventional Analysis</b>
<i>Load Combination</i>	<b>Interval End Moment (kips-inch)</b>	<b>End Moments (Kips-inch) Load Pattern A</b>	<b>End Moments (Kips-inch) Load Pattern B</b>	<b>End Moments (Kips-inch) Load Pattern C</b>
<b>1.4D</b>	[-9584.83, -9584.83]	-9584.83	-9584.83	-9584.83
<b>1.2D+1.6L</b>	[-21985.5, -5276.96]	-18564.9	-20517.3	-18843.5
<b>1.2D+L</b>	[-16821.8, -6378.94]	-14683.9	-15904.2	-14717.2
<b>1.2D+0.8W</b>	[-8145.17, -8145.17]	-8145.17	-8145.17	-8145.17
<b>1.2 D + 1.6 W + L</b>	[-16681, -6238.15]	-14543.1	-15763.4	-14717.2
<b>1.2 D + 1.0 E<sub>1</sub> + L</b>	[-15110.6, -4667.73]	-12972.7	-14192.9	-13146.8
<b>1.2 D + 1.0 E<sub>2</sub> + L</b>	[-14899.7, -4456.86]	-12761.8	-13982.1	-12936
<b>0.9 D + 1.0 E<sub>1</sub></b>	[-4623, -4623]	-4623	-4623	-4623
<b>0.9 D + 1.0 E<sub>2</sub></b>	[-4239.6, -4239.6]	-4239.6	-4239.6	-4239.6
<b>0.9 D + 1.6 W</b>	[-6020.89, -6020.89]	-6020.89	-6020.89	-6020.89
<b>Load factors as Interval</b>	[-24319, -387.651]			

**Table 20. Axial Force in column element 4 as an effect of Live Load pattern A, B and C**

<b>Column 4</b>	<b>Interval Analysis</b>	<b>Conventional Analysis</b>	<b>Conventional Analysis</b>	<b>Conventional Analysis</b>
<b>Load Combination</b>	<b>Interval Axial force (kips)</b>	<b>Axial Force (kips) Load Pattern A</b>	<b>Axial Force (kips) Load Pattern B</b>	<b>Axial Force (kips) Load Pattern C</b>
<b>1.4D</b>	[1385.81, 1385.81]	1385.81	1385.81	1385.81
<b>1.2D+1.6L</b>	[1175.96, 2765.75]	2741.33	1973.25	1971.89
<b>1.2D+L</b>	[1180.42, 2174.03]	2158.77	1678.72	1675.45
<b>1.2D+0.8W</b>	[1186.63, 1186.63]	1186.63	1186.63	1186.63
<b>1.2 D + 1.6 W + L</b>	[1177.99, 2171.61]	2156.35	1676.3	1675.45
<b>1.2 D + 1.0 E<sub>1</sub> + L</b>	[1148.5, 2142.12]	2126.86	1646.81	1645.96
<b>1.2 D + 1.0 E<sub>2</sub> + L</b>	[1118.02, 2111.63]	2096.37	1616.32	1615.47
<b>0.9 D + 1.0 E<sub>1</sub></b>	[883.911, 883.911]	883.911	883.911	883.911
<b>0.9 D + 1.0 E<sub>2</sub></b>	[828.479, 828.479]	828.479	828.479	828.479
<b>0.9 D + 1.6 W</b>	[888.457, 888.457]	888.457	888.457	888.457
<b>Load factors as Interval</b>	[838.144, 2967.48]			

**Table 21. Shear Force in column 4 as an effect of Live Load pattern A, B and C**

<b>Column 4</b>	<b>Interval Analysis</b>	<b>Conventional Analysis</b>	<b>Conventional Analysis</b>	<b>Conventional Analysis</b>
<i>Load Combination</i>	<b>Interval Shear force (kips)</b>	<b>Shear Force (kips) Load Pattern A</b>	<b>Shear Force (kips) Load Pattern B</b>	<b>Shear Force (kips) Load Pattern C</b>
<b>1.4D</b>	[186.075, 186.075]	186.075	186.075	186.075
<b>1.2D+1.6L</b>	[111.718, 417.541]	360.488	396.684	264.905
<b>1.2D+L</b>	[129.634, 320.773]	285.115	307.737	223.791
<b>1.2D+0.8W</b>	[158.7, 158.7]	158.7	158.7	158.7
<b>1.2 D + 1.6 W + L</b>	[128.049, 319.188]	283.53	306.152	223.791
<b>1.2 D + 1.0 E<sub>1</sub> + L</b>	[107.52, 298.66]	263.001	285.624	203.262
<b>1.2 D + 1.0 E<sub>2</sub> + L</b>	[103.427, 294.566]	258.908	281.53	199.169
<b>0.9 D + 1.0 E<sub>1</sub></b>	[100.856, 100.856]	100.856	100.856	100.856
<b>0.9 D + 1.0 E<sub>2</sub></b>	[93.4126, 93.4126]	93.4126	93.4126	93.4126
<b>0.9 D + 1.6 W</b>	[118.035, 118.035]	118.035	118.035	118.035
<b>Load factors as Interval</b>	[26.1216, 465.777]			

**Table 22. End Moment in column 7 as an effect of Live Load pattern A, B and C**

<b>Column 7</b>	<b>Interval Analysis</b>	<b>Conventional Analysis</b>	<b>Conventional Analysis</b>	<b>Conventional Analysis</b>
<i>Load Combination</i>	<b>Interval End Moment (kips-inch)</b>	<b>End Moments (Kips-inch) Load Pattern A</b>	<b>End Moments (Kips-inch) Load Pattern B</b>	<b>End Moments (Kips-inch) Load Pattern C</b>
<b>1.4D</b>	[-17120, -17120]	-17120	-17120	-17120
<b>1.2D+1.6L</b>	[-35710.4, -12984.6]	-33965.2	-34342.1	-16521.6
<b>1.2D+L</b>	[-27821.8, -13618.2]	-26731.1	-26966.7	-14459
<b>1.2D+0.8W</b>	[-14645.1, -14645.1]	-14645.1	-14645.1	-14645.1
<b>1.2 D + 1.6 W + L</b>	[-27763.5, -13559.9]	-26672.7	-26908.3	-14459
<b>1.2 D + 1.0 E<sub>1</sub> + L</b>	[-27012.3, -12808.7]	-25921.6	-26157.1	-13707.8
<b>1.2 D + 1.0 E<sub>2</sub> + L</b>	[-26635.7, -12432.1]	-25544.9	-25780.5	-13331.2
<b>0.9 D + 1.0 E<sub>1</sub></b>	[-10504.3, -10504.3]	-10504.3	-10504.3	-10504.3
<b>0.9 D + 1.0 E<sub>2</sub></b>	[-9819.55, -9819.55]	-9819.55	-9819.55	-9819.55
<b>0.9 D + 1.6 W</b>	[-10947.4, -10947.4]	-10947.4	-10947.4	-10947.4
<b>Load factors as Interval</b>	[-38690.1, -7879.94]			

**Table 23. Axial Force in column 7 as an effect of Live Load pattern A, B and C**

<b>Column 7</b>	<b>Interval Analysis</b>	<b>Conventional Analysis</b>	<b>Conventional Analysis</b>	<b>Conventional Analysis</b>
<i>Load Combination</i>	<b>Interval Axial force (kips)</b>	<b>Axial Force (kips) Load Pattern A</b>	<b>Axial Force (kips) Load Pattern B</b>	<b>Axial Force (kips) Load Pattern C</b>
<b>1.4D</b>	[338.857, 338.857]	338.857	338.857	338.857
<b>1.2D+1.6L</b>	[275.775, 688.048]	676.414	681.523	282.461
<b>1.2D+L</b>	[281.278, 538.948]	531.677	534.87	285.108
<b>1.2D+0.8W</b>	[290.274, 290.274]	290.274	290.274	290.274
<b>1.2 D + 1.6 W + L</b>	[280.929, 538.599]	531.328	534.521	285.108
<b>1.2 D + 1.0 E<sub>1</sub> + L</b>	[276.904, 534.574]	527.303	530.496	281.082
<b>1.2 D + 1.0 E<sub>2</sub> + L</b>	[269.449, 527.119]	519.848	523.041	273.627
<b>0.9 D + 1.0 E<sub>1</sub></b>	[219.562, 219.562]	219.562	219.562	219.562
<b>0.9 D + 1.0 E<sub>2</sub></b>	[206.007, 206.007]	206.007	206.007	206.007
<b>0.9 D + 1.6 W</b>	[217.488, 217.488]	217.488	217.488	217.488
<b>Load factors as Interval</b>	[193.125, 741.093]			

**Table 24. Shear Force in column 7 as an effect of Live Load pattern A, B and C**

<b>Column 7</b>	<b>Interval Analysis</b>	<b>Conventional Analysis</b>	<b>Conventional Analysis</b>	<b>Conventional Analysis</b>
<i>Load Combination</i>	<b>Interval Shear force (kips)</b>	<b>Shear Force (kips)</b> <b>Load Pattern A</b>	<b>Shear Force (kips)</b> <b>Load Pattern B</b>	<b>Shear Force (kips)</b> <b>Load Pattern C</b>
<b>1.4D</b>	[193.168, 193.168]	193.168	193.168	193.168
<b>1.2D+1.6L</b>	[129.096, 420.338]	385.646	333.921	227.535
<b>1.2D+L</b>	[142.775, 324.801]	303.119	270.79	203.878
<b>1.2D+0.8W</b>	[165.362, 165.362]	165.362	165.362	165.362
<b>1.2 D + 1.6 W + L</b>	[142.353, 324.379]	302.697	270.369	203.878
<b>1.2 D + 1.0 E<sub>1</sub> + L</b>	[137.617, 319.642]	297.96	265.632	194.891
<b>1.2 D + 1.0 E<sub>2</sub> + L</b>	[133.367, 315.393]	293.711	261.382	194.891
<b>0.9 D + 1.0 E<sub>1</sub></b>	[122.498, 122.498]	122.498	122.498	122.498
<b>0.9 D + 1.0 E<sub>2</sub></b>	[114.771, 114.771]	114.771	114.771	114.771
<b>0.9 D + 1.6 W</b>	[123.758, 123.758]	123.758	123.758	123.758
<b>Load factors as Interval</b>	[62.6055, 467.065]			

Table 16, 19 and 22 show that for a given load combination and a given load pattern, end moments increase from lower floor columns to upper floor columns. However table 17, 20 and 23 shows that axial force decreases from lower level columns to upper level columns. Additionally, the same nature of behavior can be observed for the lower and upper bounds of the interval response. Alternatively, it can be deduced that for a given load combination and a given load pattern, the lower bound on end moments decreases from lower level columns to upper level columns and at the same time the upper bound on column end moments increase from lower level column to upper level column. Consequently, for a given load combination that involves a live load, the width of the interval moments increases from lower level column to upper level column.

## **8. COMPARATIVE STUDY OF INTERVAL FE & CONVENTIONAL ANALYSIS: EFFECTS OF NUMBER OF FLOOR**

In this section, structure will be analyzed for varying height and objective is to identify the nature of deviation between interval response and conventional structural response. The frame that we have been using since last section will be considered once again. This frame will be modified to increase number of floors up to ten and fifteen. Structure will be analyzed under various load combinations, first for interval finite element analysis and then we will study the same parameters for few chosen representative load patterns. A comparative study will be presented in order to show advantages of interval FE analysis over what has been suggested conventionally by various structural engineering code practices.

### **8.1 Case A: Number of Floors = 10**

Following points need to be reiterated for modified frame.

- 1) Three floors are being added on the top of existing original frame.
- 2) Each of the added are of height 11 ft 4 inch.
- 3) Properties of added beams and columns are same as that of the top floor of original frame.
- 4) Dead load and Live load for added floor is same as of previously existing floors.
- 5) Weight of the structure has been increased in proportion to number of floors.
- 6) Earthquake loads have been calculated based on IBC code of practices.

7) Wind load have been revised for modified structure using ASCE6 codes of practices.

Once again analyze modified frame will be analyzed for three different cases. Case A corresponds to maximum span moment in a beam, Case B refers to minimum span moment in the same beam and Case 3 focuses on a column element. Modified values of earthquake force and wind force acting on modified frame need to be re-calculated before structure can be analyzed for load combinations and load patterns.

**Table 25 a. Earthquake load calculation for modified frame (ten floor frame)**

Story	Story Height	Story Height from Base $h_i$	$h_i^k$	$C_{vx}$
1	16	16	21.11	0.0240
2	8.66	24.66	33.98	0.0387
3	8.66	33.33	47.33	0.0539
4	8.66	42	61.03	0.0696
5	8.66	50.66	75.02	0.0855
6	8.66	59.33	89.25	0.1017
7	11.33	70.66	108.17	0.1233
8	11.33	82	127.40	0.1452
9	11.33	93.33	146.90	0.1675
10	11.33	104.66	166.64	0.1900
		Total	876.87	

Table 25a and 25b show necessary calculation in order to evaluate earthquake load as statically equivalent joint load acting on various nodes. It is important to note that actual earthquake force that appears in various load combination includes combined effect of this horizontal force and additionally vertically induced force due to dead load as well.

**Table 25 b. Earthquake Load Calculation for modified frame (ten floors frame)**

Static Equivalent of Earthquake Load	
$W = 5714.28$ Kips	
$C_s = 0.0831$	
$V = 474.8571429$ Kips	
Floor $i$	Joint Load At floor $i$ , $V_i$ (kips)
1	11.43
2	18.40
3	25.63
4	33.051
5	40.62
6	48.33
7	58.58
8	68.99
9	79.55
10	90.24

**Table 26. Wind Load Calculation for modified frame (ten floor frame)**

Calculate the static equivalent of wind pressure		
Effective Width	21	
Height	Pressure	Design Wind Load
Ft	P s f	Kips
0	14.77	
16	14.77	4.96
24.66	14.77	2.68
33.33	14.77	2.68
42	14.77	2.68
50.67	14.77	2.68
59.33	14.77	2.68
70.67	14.77	3.51
82	14.77	3.51
93.333	14.77	3.51
104.66	15.85	3.64

**Table 27. Summary of Earthquake Load and Wind Load for modified frame (ten floors)**

	Summary of Loads		
<b>Dead Load</b>	U.D.L at all beam	18.2 kips/ft	
<b>Live Load</b>	U.D.L at all beam	18 kips/ft	
<i>Earthquake Load</i>	Joint Load		
<i>Wind Load</i>	Joint Load		
<i>Joint</i>	<i>Height (ft)</i>	<b>Earthquake Load (kips)</b>	<b>Wind Load (kips)</b>
2	16	11.43	4.96
3	24.66	18.4	2.68
4	33.33	25.63	2.68
5	42	33.05	2.68
6	50.67	40.62	2.68
7	59.33	48.33	2.68
8	70.67	58.58	3.51
9	82	68.99	3.51
10	93.33	79.55	3.51
11	104.66	90.24	3.64

		62		65		68			77	
59										
58										
	60		63		66		69		72	75
57										
	16		24		32		40		48	
8										56
7										55
6										54
5										53
4										52
	11									
3										51
	10									
2										50
1										
	9		17		25		33		41	49

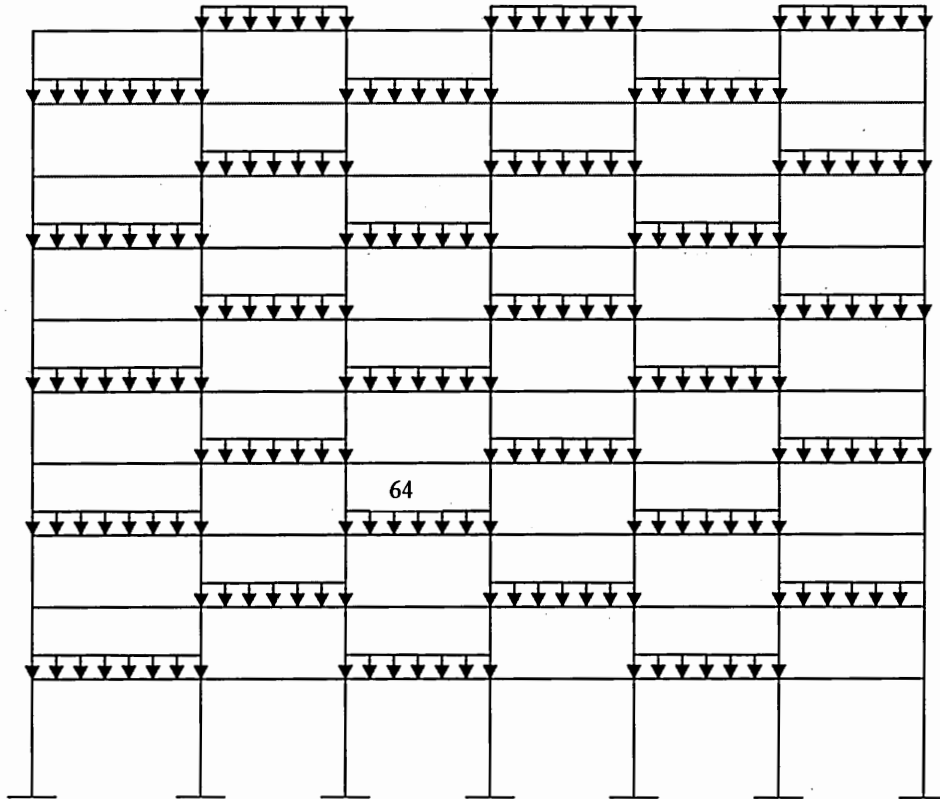
**Figure 8.1. Joints numbering for ten floors frame**

	<u>125</u>					<u>130</u>	
<u>94</u>	<u>97</u>	<u>100</u>	<u>103</u>	<u>106</u>	<u>109</u>		<u>112</u>
<u>93</u>	<u>113</u> <u>96</u>	<u>114</u> <u>99</u>	<u>115</u> <u>102</u>	<u>116</u> <u>105</u>	<u>117</u> <u>108</u>	<u>118</u>	111
<u>92</u>	<u>86</u> <u>95</u>	<u>98</u>	<u>101</u>	<u>104</u>	<u>107</u>	<u>91</u> <u>110</u>	
<u>7</u>							49
<u>6</u>							
<u>5</u>							
<u>4</u>			<u>64</u>				
<u>3</u>	<u>56</u>		<u>24</u>				
<u>2</u>	<u>50</u>	<u>51</u>	<u>52</u>	<u>53</u>	<u>54</u>	<u>55</u>	
<u>1</u>	<u>8</u>	<u>15</u>	<u>22</u>	<u>29</u>	<u>36</u>		<u>43</u>

**Figure 8.2. Frame elements numbering for ten floors frame.**

### 8.1.1 Case 1- Maximum Span Moment of a Beam

Maximum span moment in a beam for the modified ten floors structure is the primary focus of this subsection.



**Figure 9.1. Case 1: Live load pattern for maximum span moment in beam – ten floors frame**

**Table 28. Maximum Span Moment in beam 64(ten floor frame)**

<b>Beam 64</b>	<b>Interval Analysis</b>	<b>Conventional Analysis</b>
<b>Load Combination</b>	<b>Interval Span Moment (kips-inch)</b>	<b>Maximum Span Moment (kips-inch)</b>
<b>1.4D</b>	[9297, 9297]	9297
<b>1.2D+1.6L</b>	[7009, 19430]	19410
<b>1.2D+L</b>	[7369, 15130]	15120

For the current ten-floor frame, span moments have been again evaluated using Interval FE analysis and load pattern as shown in Figure 9.1. The first load combination (1.4D) has the same lower and upper bound of interval span moment and it matched with what load pattern has calculated. This is simply due to the fact that there is no live load pattern involved. However, other two load combinations have different lower and upper bounds of interval span moment (table 28) as they involve effect of live load pattern, maximum span moment for load pattern in consideration is again within the interval.

### **8.1.2 Case 2- Minimum Span Moment of a Beam**

In this subsection interval finite element analysis is being compared with conventional load pattern analysis through analyzing modified ten-frame structure for the minimum span moments in the beam.

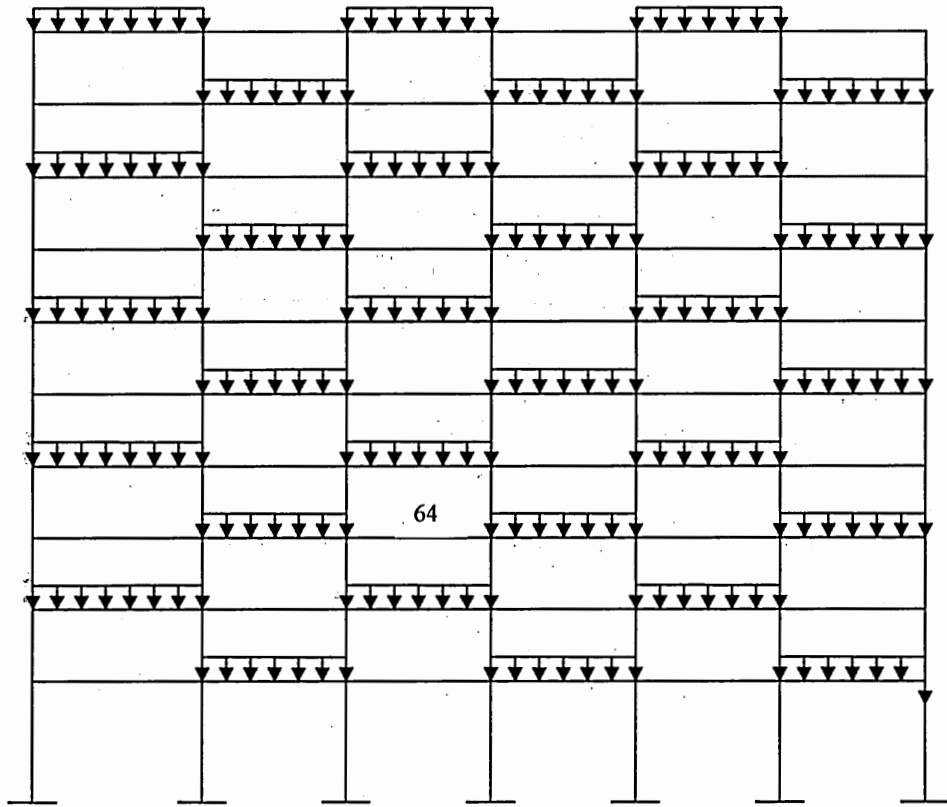


Figure 9.2. Case 2: Live load pattern for minimum span moment in beam – ten-floor frame

Table 29. Minimum Span Moment in beam 64 (10 floor frame)

Beam 64	Interval Analysis	Conventional Analysis
<i>Load Combination</i>	Interval Span Moment (kips-inch)	Minimum Span Moment (kips-inch)
1.4D	[9297, 9297]	9297
1.2D+1.6L	[7009, 19430]	7030
1.2D+L	[7369, 15130]	7382

Interval FE analysis still hold the same result for ten-floor frame as far as span moment in beam 64 is concerned as this analysis cover all the load pattern in itself by the nature of interval arithmetic however, engineer would like to consider a different load pattern for analyzing the beam 64. Load pattern shown in Figure 9.2 is most general load pattern that is being widely used in industry and also being suggested by various codes of practices (see chapter for load combinations and load patterns), in this load pattern beam in consideration is unloaded and every alternative beam is also unloaded. This will give minimum span moment in beam under consideration and table 29 shows that this is contained within interval span moment.

### 8.1.3 Case 3 - Comparison for Maximum End Moments for Column 8

Once again, following three load patterns are being considered in order to get the maximum and minimum end moments at the end of column. Column in which we are interested is member 8.

#### Load Pattern A

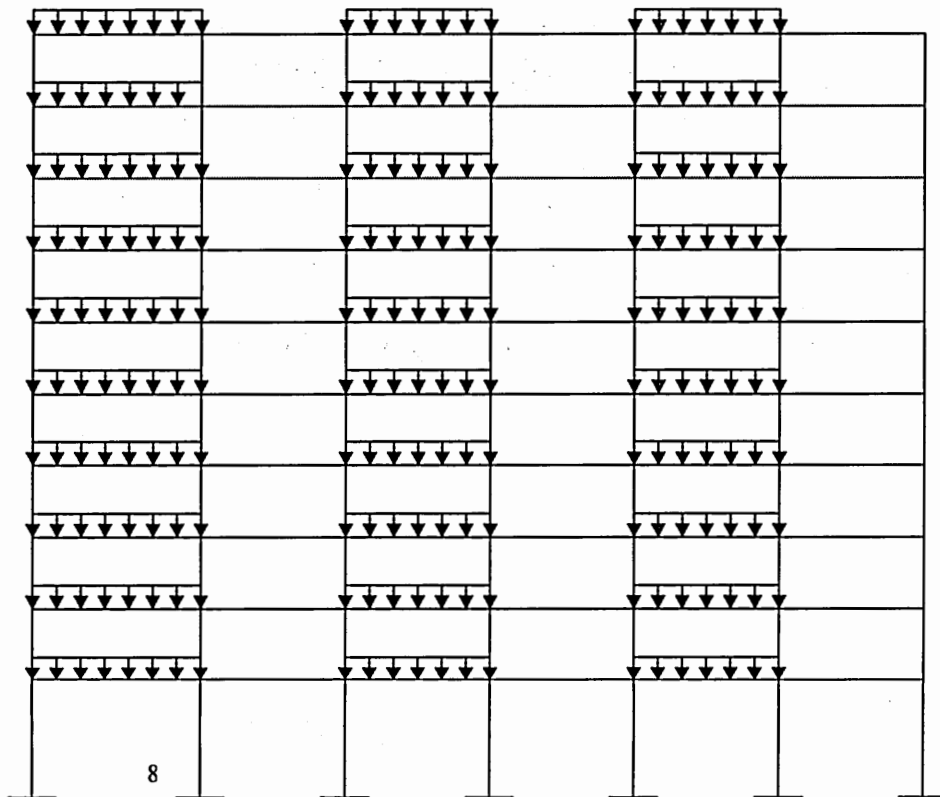


Figure 9.3. Case 3: Live load pattern A for end moment at the end of column element – ten floors frame

**Table 30. End Moments in column 8 as an effect of Live Load Pattern A, B and C (ten-floor frame)**

	Interval Analysis	Conventional Analysis		
		Load pattern A	Load pattern B	Load pattern C
<i>Load Combination</i>	Interval End Moment (Kips-inch)	End Moment (Kips-inch)	End Moment (Kips-inch)	End Moment (Kips-inch)
<b>1.4D</b>	[-1390.09, -1390.09]	-1390.09	-1390.09	-1390.09
<b>1.2D+1.6L</b>	[-12495.5, 8541.63]	4847.61	-8464.98	-11687.2
<b>1.2D+L</b>	[-8256.52, 4891.7]	2582.94	-5737.43	-7751.31
<b>1.2D+0.8W</b>	[-981.16, -981.16]	-981.16	-981.16	-981.16
<b>1.2 D + 1.6 W + L</b>	[-7835.82, 5312.4]	3003.64	-5316.73	-7330.61
<b>1.2 D + 1.0 E<sub>1</sub> + L</b>	[-4887.83, 8260.4]	5951.64	-2368.74	-4382.61
<b>1.2 D + 1.0 E<sub>2</sub> + L</b>	[-4857.24, 8290.98]	5982.22	-2338.15	-4352.03
<b>0.9 D + 1.0 E<sub>1</sub></b>	[2450.04, 2450.04]	2450.04	2450.04	2450.04
<b>0.9 D + 1.0 E<sub>2</sub></b>	[2505.64, 2505.64]	2505.64	2505.64	2505.64
<b>0.9 D + 1.6 W</b>	[-472.932, -472.932]	-472.932	-472.932	-472.932
<b>Load factors as Interval</b>	[-15770.2, 15707.8]			

## Live Load Pattern B

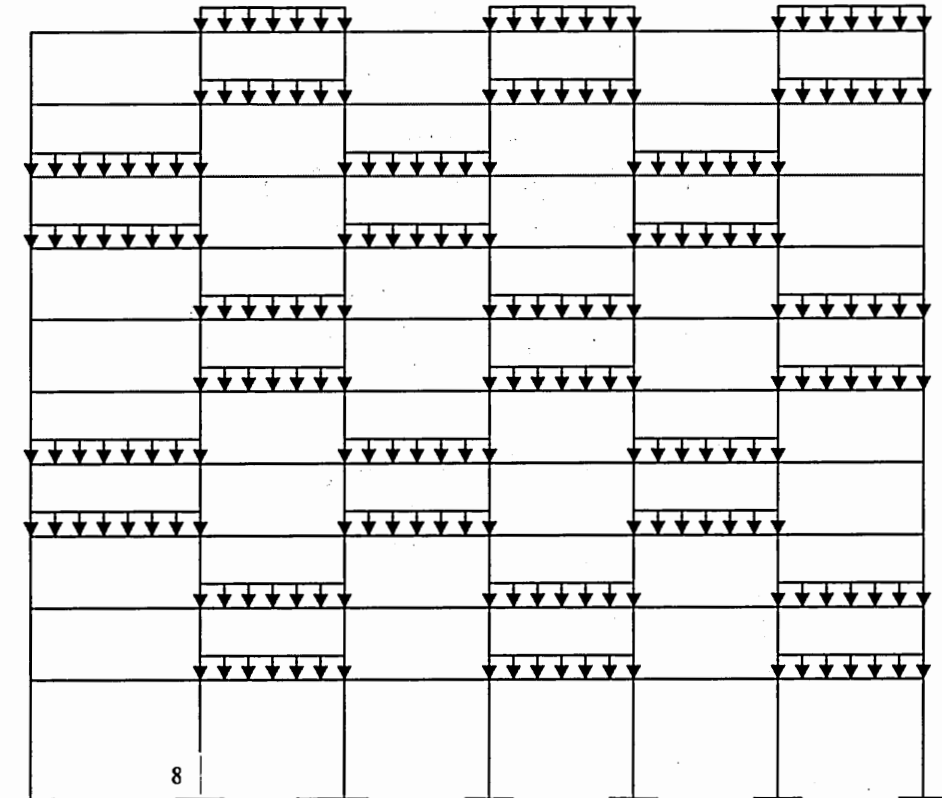
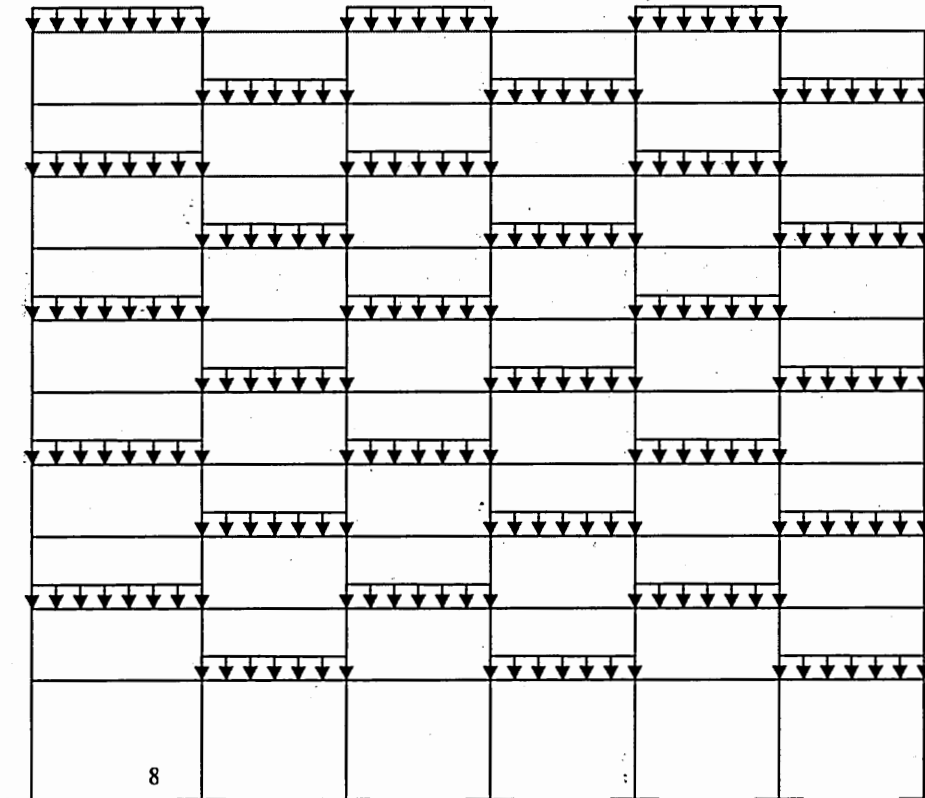


Figure 9.4. Case 3: Live load pattern B for end moment at the end of column— ten floors frame

## Live Load Pattern C



**Figure 9.5. Case 3: Live load pattern C for end moment at the end of column— ten floors frame**

It is important to note that in real practice analyzing a structure for three load pattern just in order to get maximum or minimum end moment in one particular column may prove to be a tiresome task and since using all possible load pattern for such cases are so computation intensive and require enormous man time and computer time, it makes it almost an impossible and impractical task.

Table 22 shows that interval end moment width obtained in column 8 for every load pattern and load combination is increasing (e.g. compare table 14 and 22) and it is not difficult to show that it hold true for all the column and for all the structural parameter like axial force, bending moment, axial force and then for every structural element as beam or column. These results will be later explained in details in conclusion section.

## **8.2 Case B: Number of Floor = 15**

1. Five floors have been added on the top of previously existing ten floors frame to form a fifteen story portal frames.
2. Each of the added are of height 11 ft 4 inch.
3. Numbering of added joints and members is being in such a way so that joints and members that we had in Case B, holds the same number, for the new ones, column is being numbered first and then all remaining beams. This way there is a minimal change to the input file.
4. Dead load and Live load for added floor is same as of previously existing floors.
5. Weight of the structure has been increased in proportion to number of floors.
6. Earthquake loads have been calculated based on IBC code of practices.
7. Wind load have been revised for modified structure using ASCE6 codes of practices.

**Table 31 a. Earthquake load calculation for modified frame (fifteen floors frame)**

Story	Story Height	Story Height from Base $h_i$	$h_i^k$	$C_{vx}$
1	16	16	21.11	0.01048
2	8.66	24.66	33.98	0.01688
3	8.66	33.33	47.33	0.02351
4	8.66	42	61.03	0.03031
5	8.66	50.66	75.02	0.03726
6	8.66	59.33	89.25	0.04433
7	11.33	70.66	108.17	0.05373
8	11.33	82	127.40	0.0632
9	11.33	93.33	146.90	0.07297
10	11.33	104.66	166.64	0.0827
11	11.33	116	186.59	0.09269
12	11.33	127.33	206.74	0.10270
13	11.33	138.66	227.07	0.11279
14	11.33	150	247.57	0.12298
15	11.33	161.33	268.22	0.1332
		Total	2013.09	

**Table 31 b. Earthquake load calculation for modified frame (fifteen floor frame)**

Static Equivalent of Earthquake Load	
$W = 8571.428571$ Kips	
$C_s = 0.0831$	
$V = 712.2857143$ Kips	
Floor $i$	Joint Load At floor $i$ , $V_i$ (kips)
1	7.47
2	12.02
3	16.74
4	21.59
5	26.54
6	31.58
7	38.27
8	45.08
9	51.97
10	58.96
11	66.02
12	73.15
13	80.34
14	87.59
15	94.90

**Table 32. Wind load calculation for modified frame (fifteen floor frame)**

Effective Width	21	
Height	Pressure	Design Wind Load
Ft	P s f	Kips
0	14.77	
16	14.77	4.961
24.66	14.77	2.687
33.33	14.77	2.687
42	14.77	2.687
50.66	14.77	2.687
59.33	14.77	2.687
70.66	14.77	3.514
82	14.77	3.514
93.33	14.77	3.514
104.66	15.85	3.643
116	15.85	3.773
127.33	16.94	3.902
138.66	16.94	4.031
150	17.81	4.134
161.33	18.68	4.341

**Table 33. Summary of Earthquake load and Wind load for modified frame (fifteen floor frame)**

Dead Load	U.D.L at all beam	18.2 kips/ft	
Live Load	U.D.L at all beam	18 kips/ft	
Earthquake and wind Load	Joint Load		
Joint	Height (ft)	Earthquake Load (kips)	Wind Load (kips)
2	16	7.47	4.961
3	24.66	12.02	2.687
4	33.33	16.74	2.687
5	42	21.59	2.687
6	50.67	26.54	2.687
7	59.33	31.58	2.687
8	70.67	38.27	3.514
9	82	45.08	3.514
10	93.33	51.97	3.514
11	104.66	58.96	3.643
12	104.66	66.02	3.773
13	104.66	73.15	3.902
14	104.66	80.34	4.031
15	104.66	87.59	4.1349
16	104.66	94.9	4.341

	87	92	97	102	107	
82						112
81						111
80						110
79						109
78	83	88	93	98	103	108
59	62	65	68	71	74	77
58						
57	60	63	66	69	72	75
8	16	24	32	40	48	56
7						55
6						54
5						53
4						52
3	11					51
2	10					50
1	9	17	25	33	41	49

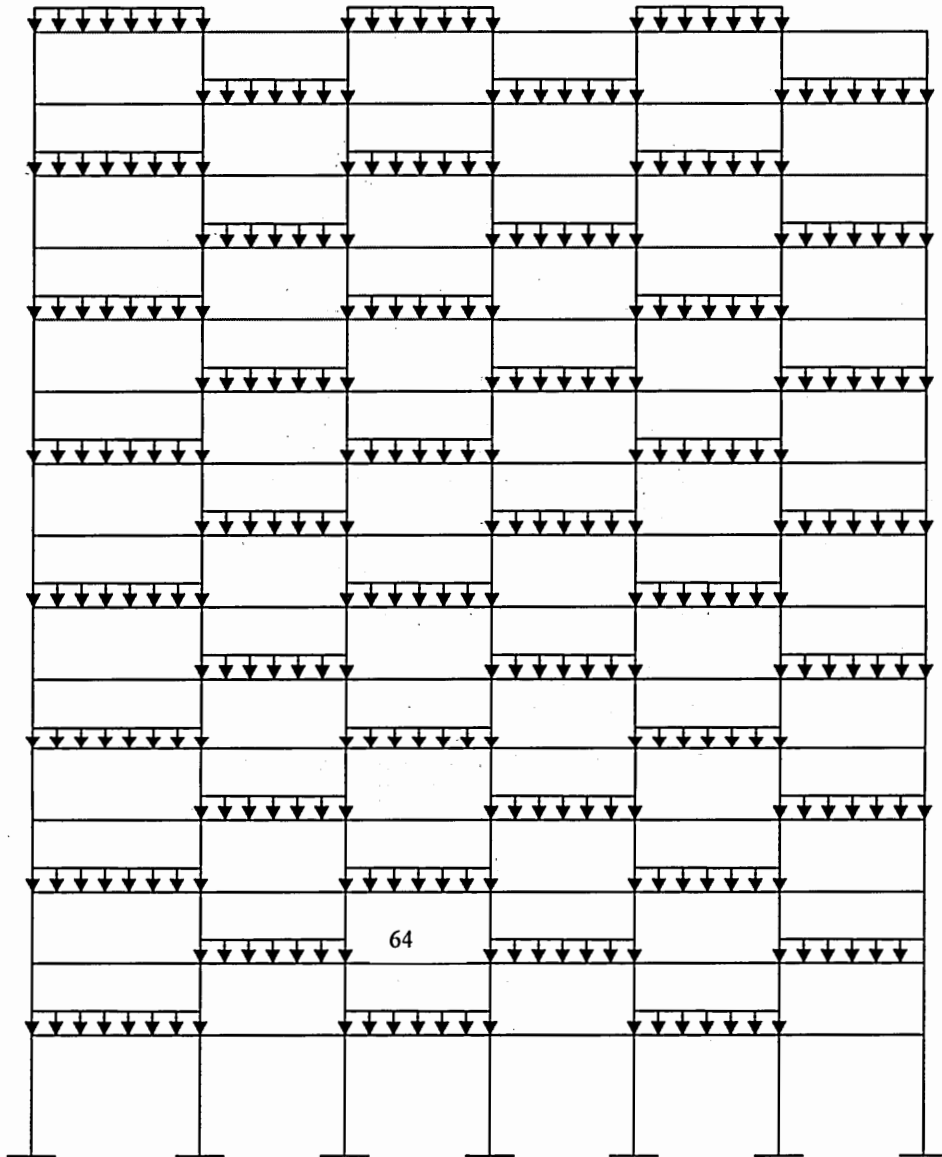
**Figure 10.1. Joints numbering for fifteen-floor portal frame**

	<u>190</u>	<u>191</u>	<u>192</u>	<u>193</u>	<u>194</u>	<u>195</u>	
<u>135</u>	<u>140</u>	<u>145</u>					<u>165</u>
<u>134</u>							<u>164</u>
<u>133</u>							<u>163</u>
<u>132</u>	<u>166</u>	<u>167</u>	<u>168</u>	<u>169</u>	<u>170</u>	<u>171</u>	<u>162</u>
<u>131</u>	<u>125</u>		<u>127</u>			<u>130</u>	<u>161</u>
<u>94</u>	<u>97</u>	<u>100</u>	<u>103</u>	<u>106</u>	<u>109</u>		<u>112</u>
<u>93</u>	<u>113</u> <u>96</u>	<u>99</u>	<u>102</u>	<u>105</u>	<u>108</u>	<u>118</u>	<u>111</u>
<u>92</u>	<u>86</u> <u>95</u>	<u>98</u>	<u>101</u>	<u>104</u>	<u>107</u>	<u>91</u>	<u>110</u>
<u>7</u>							<u>49</u>
<u>6</u>							
<u>5</u>							
<u>4</u>			<u>64</u>				
<u>3</u>	<u>56</u>		<u>24</u>				
<u>2</u>	<u>50</u>	<u>51</u>	<u>52</u>	<u>53</u>	<u>54</u>	<u>55</u>	
<u>1</u>	<u>8</u>	<u>15</u>	<u>22</u>	<u>29</u>	<u>36</u>		<u>43</u>

**Figure 10.2. Frame elements numbering for fifteen floor frame**

### 8.2.1 Case 1 - Maximum Span Moment for Beam

In this section maximum span moment is being calculated in a beam 64, first through interval FE analysis for 3 load combinations and then same member will be analyzed for the load pattern shown in Figure 11.1.



**Figure 11.1. Case 1: live load pattern for maximum span moment in beam– fifteen-floor frame**

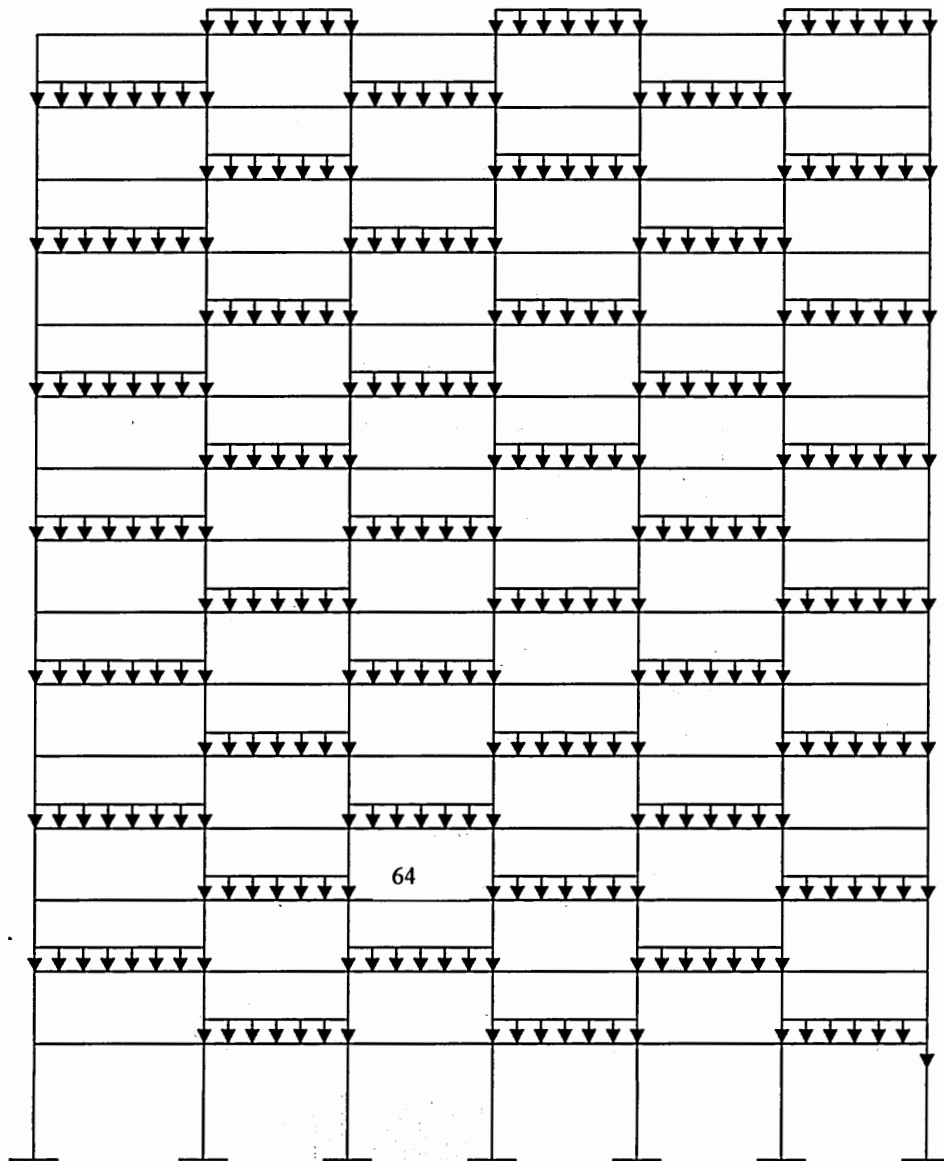
As before this time again a load pattern that is conventionally being used for maximizing span moment in beams, will be considered (Figure 11.2). Note that interval width has increased as compared to what was obtained in seven floor or ten floor cases in earlier sections (Table 10, 18 and 26). This is because of the fact that Interval FE analysis of fifteen-floor frame covers  $2^{90}$  load patterns while seven and ten floor had  $2^{42}$  and  $2^{60}$  hence it cause lower and upper limit of span moment to deviate. However, maximum span moment from conventional analysis can deviate in either way depending upon the ratio of dead load and live load. In later part of work it will be shown about how the maximum and minimum values of parameters such as span moment or end moment in a member deviate from lower and upper limit of corresponding interval value.

**Table 34. Maximum span moment in beam 64 (fifteen floors frame)**

Beam 64	Interval Analysis	Conventional Analysis
Load Combination	Interval Span Moment (kips-inch)	Maximum Span Moment (kips-inch)
1.4D	[9293, 9293]	9293
1.2D+1.6L	[6991, 19440]	19410
1.2D+L	[7356, 15140]	15120

**8.2.2 Case 2 - Minimum Span Moment for Beam**

Same frame has been analyzed for load pattern that cause minimum span moment in beam. Same beam element has been picked up for the minimum span moment and only three load combinations have been picked up.



**Figure 11.2. Case 2: Live load pattern for minimum span moment in beam element – fifteen floors frame**

It is important to note that results from interval FE analysis contain the results from conventional analysis but difference between maximum span moment and upper limit of interval span moment (Table 26) or minimum span moment and lower limit of interval span moment (Table 27) is not significant enough, this is the reason that efforts has not

been put for analysis of all the 10 load combination, however column end moment show a significant difference in this regard and hence in such cases results from all the 10 load combinations are being used.

**Table 35. Minimum span moment in beam 64 (fifteen floor frame)**

<b>Beam 64</b>	<b>Interval Analysis</b>	<b>Conventional Analysis</b>
<i>Load Combination</i>	<b>Interval Span Moment (kips-inch)</b>	<b>Minimum Span Moment (kips-inch)</b>
<b>1.4D</b>	[9293, 9293]	9293
<b>1.2D+1.6L</b>	[6991, 19440]	7025
<b>1.2D+L</b>	[7356, 15140]	7378

### 8.2.3 Case 3 - Comparison for End Moments in Column 8

In this case maximum and minimum end moments in column 8 are design parameters. Three live load patterns will be taken into consideration in order to analyze column conventionally. Figure 11.3, 11.4 and 11.5 shows live load pattern A, B and C.

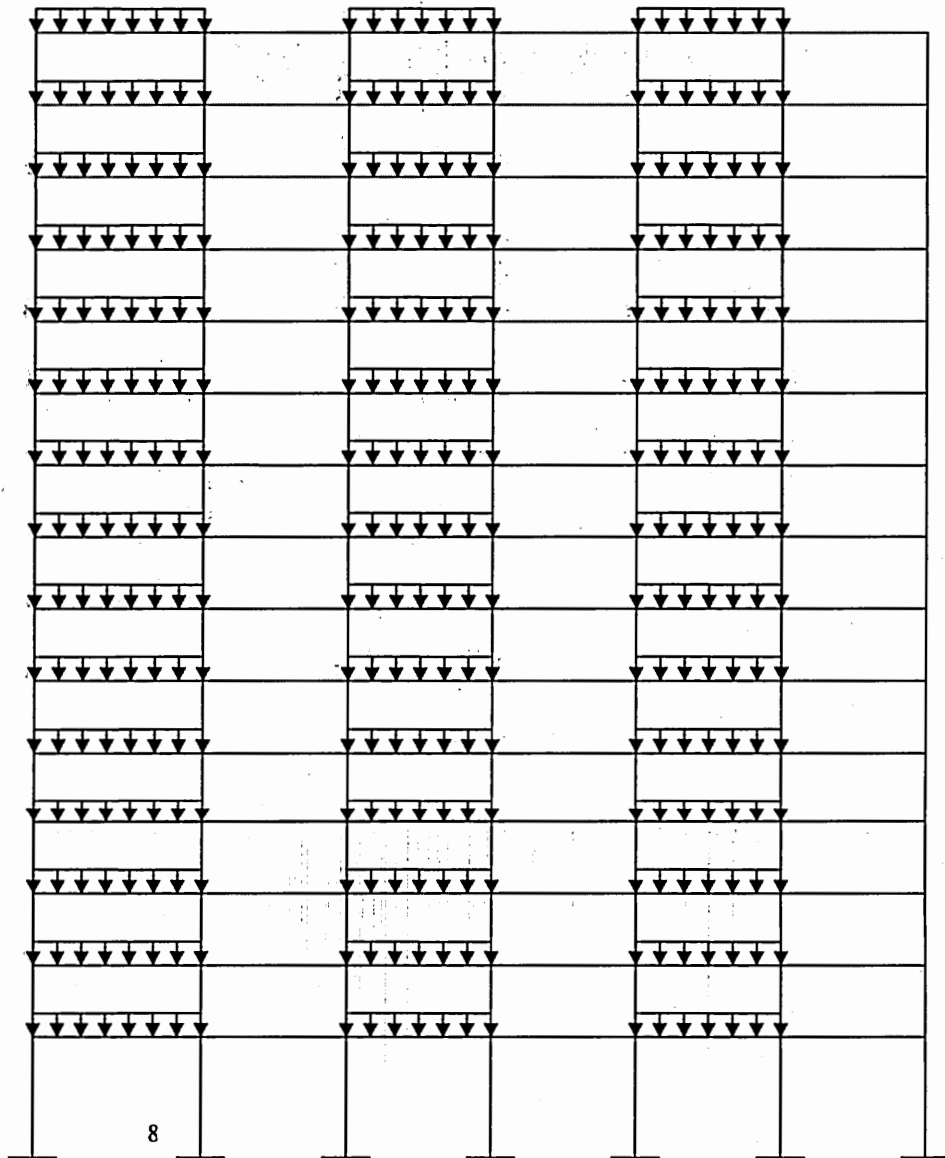
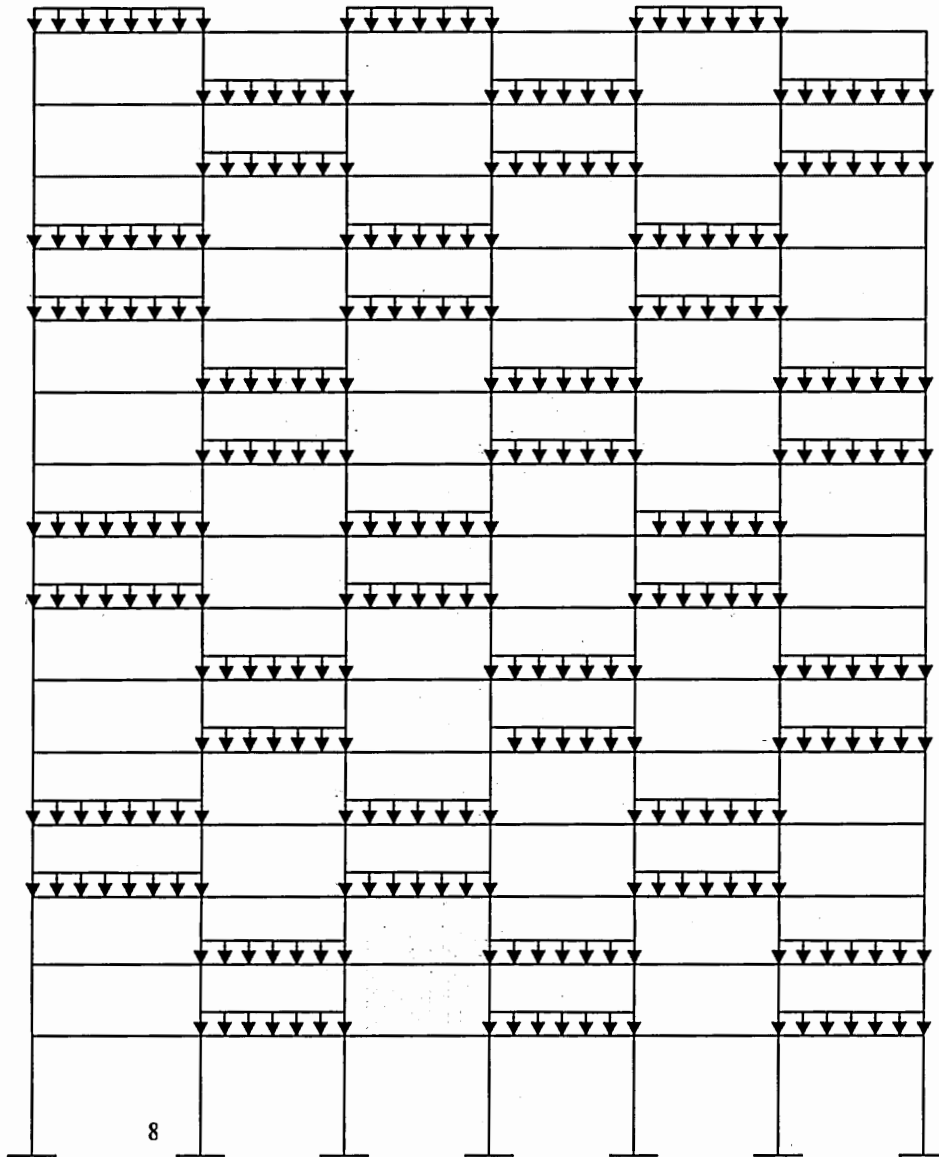


Figure 11.3. Case 3: Live load pattern A for maximum/minimum end moment in column- fifteen-floor frame

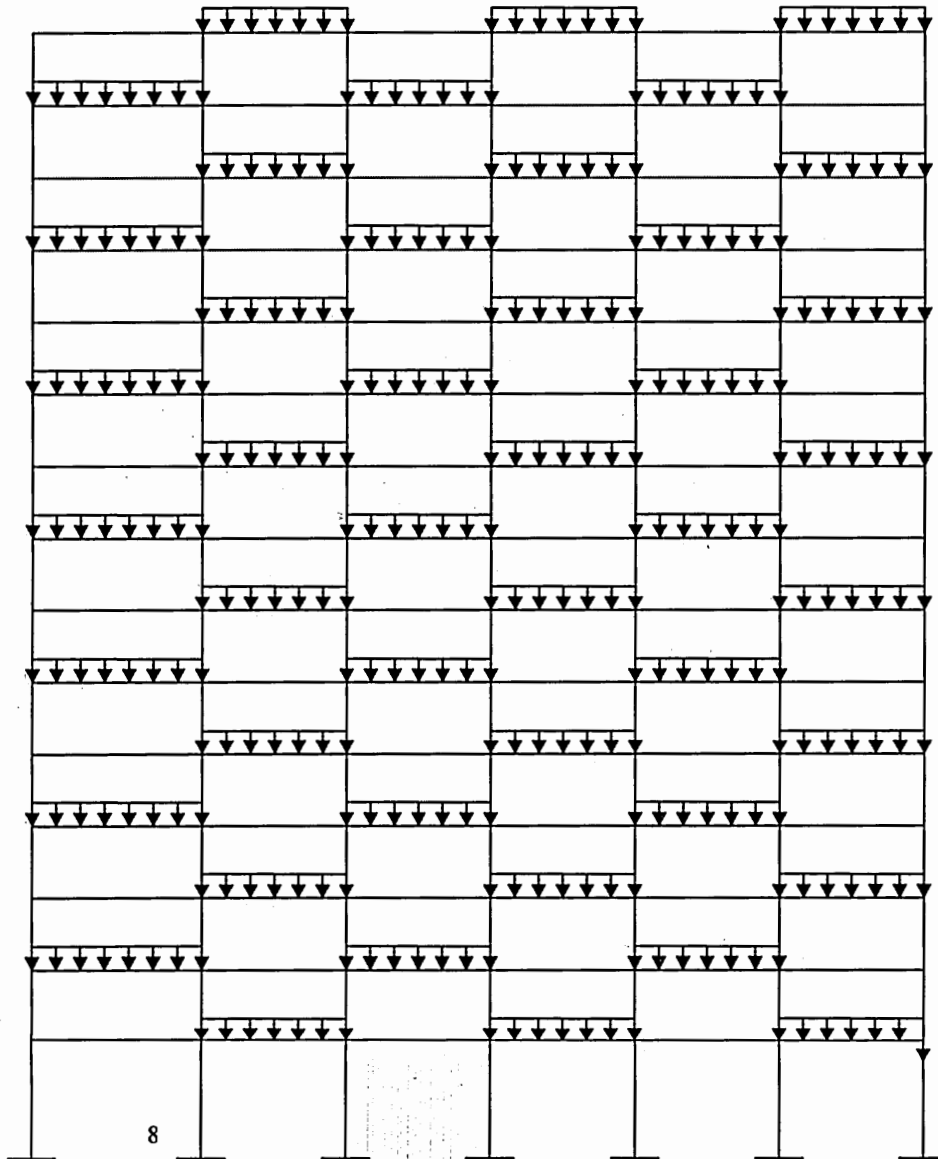
Results from Interval FE Analysis will then be compared for upper and lower bound of interval end moments obtained from these three load patterns.



**Figure 11.4. Case 3: Live load pattern B for maximum/minimum end moment in column– fifteen-floor frame**

**Table 36. End Moment in Column 8 as per effect of Live Load Pattern A, B and C  
(fifteen floor frame)**

Column 8	Interval Analysis	Conventional Analysis		
		Load Pattern A	Load Pattern B	Load Pattern C
<i>Load Combination</i>	Interval End Moment (Kips-inch)	End Moment (Kips-inch)	End Moment (Kips-inch)	End Moment (Kips-inch)
<b>1.4D</b>	[-1542.88, -1542.88]	-1542.88	-1542.88	-1542.88
<b>1.2D+1.6L</b>	[-12968, 8579.49]	4715.4	-8662.33	-11923.8
<b>1.2D+L</b>	[-8600.9, 4866.26]	2451.2	-5909.88	-7948.28
<b>1.2D+0.8W</b>	[-1000.84, -1000.84]	-1000.84	-1000.84	-1000.84
<b>1.2 D + 1.6 W + L</b>	[-7957.64, 5509.52]	3094.46	-5266.62	-7305.02
<b>1.2 D + 1.0 E<sub>1</sub> + L</b>	[-3647.8, 9819.36]	7404.3	-956.777	-2995.18
<b>1.2 D + 1.0 E<sub>2</sub> + L</b>	[-3613.85, 9853.3]	7438.25	-922.833	-2961.23
<b>0.9 D + 1.0 E<sub>1</sub></b>	[3933.48, 3933.48]	3933.48	3933.48	3933.48
<b>0.9 D + 1.0 E<sub>2</sub></b>	[3995.19, 3995.19]	3995.19	3995.19	3995.19
<b>0.9 D + 1.6 W</b>	[-348.592, -348.592]	-348.592	-348.592	-348.592
<b>Load factors as Interval</b>	[-16317.8, 17639]			



**Figure 11.5. Case 3: Live load pattern C for maximum/minimum end moment in column– fifteen-floor frame**

Results obtained from three conventional load patterns analysis and their comparison with interval FE analysis has been explained in details in subsequent section. However, all the results obtained until this point clearly shows that interval analysis guarantee to

contain the results from all possible load pattern and it hold equally valid for all type of load combinations. How close conventional analysis results can lie to the lower or upper bound of interval results is still a moot point as exact nature of deviation of conventional results from the bound of interval response, will depend on the type of load combination, ratio of dead load to live load, ratio of horizontal to vertical forces and on structural member properties itself. However, in next chapter efforts have been made in order to study the nature of such deviations.

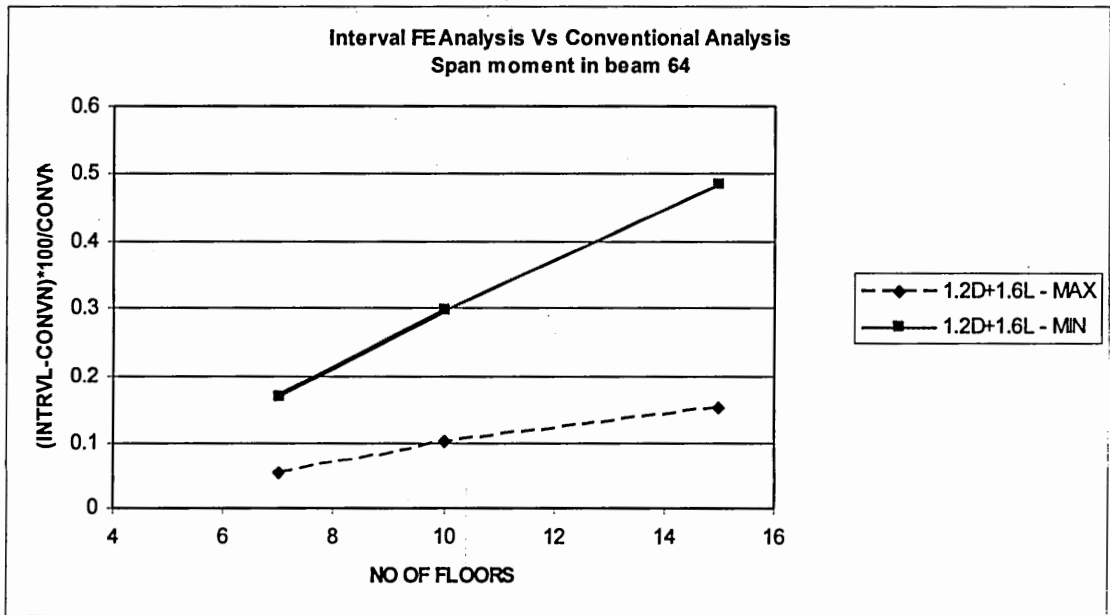
## 9. DISCUSSION

In this section, results from all previous Interval FE Analysis and various conventional load pattern analysis that had already been done, will be studied in detail. Table 31 focus on beam element (beam 64), in the column A of table 31, interval span moments are being listed for three load combinations and for three type of frames, seven floors, ten floors and fifteen floors frame. First of all it is interesting to see that lower bound of interval span moment decreases and at the same time upper bound increase numbers of floors are increased. It happened because of the fact of increase in live load pattern that Interval FE analysis is accounting for.

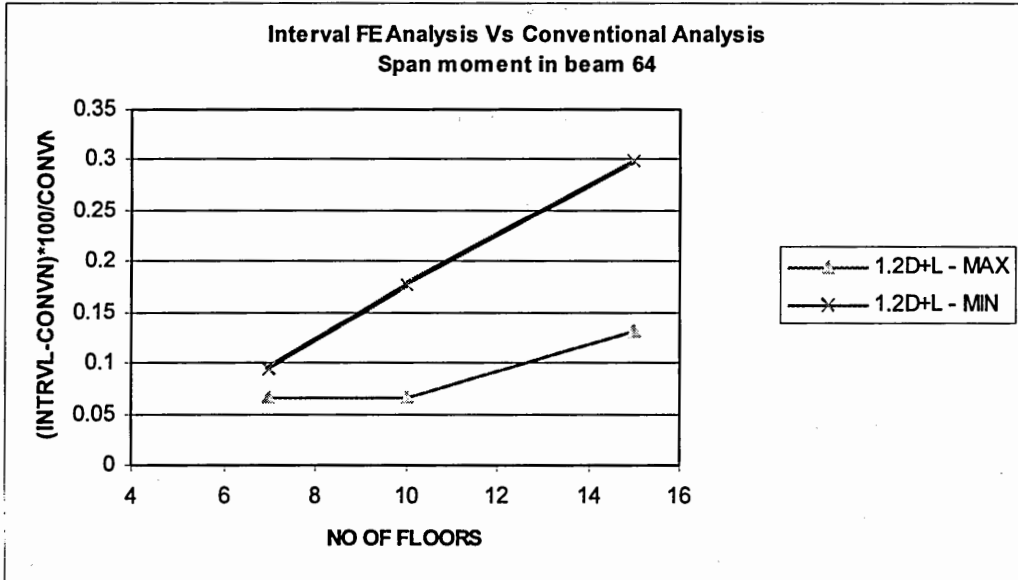
**Table 37. Beam 64: Percentage deviation Vs number of floor**

Comparison for Span Moment	Floors	Beam 64				
		Column A	Column B		Column C	
		Interval FE Analysis	Conventional Analysis		% Deviation	
		Interval FE Span Moment	Minimum	Maximum	Maximum	Minimum
Load Combination 1.2D + 1.6L	7	[7016, 19420]	7028	19410	0.05152	0.170746
	10	[7009, 19430]	7030	19410	0.10304	0.29872
	15	[6991, 19440]	7025	19410	0.15456	0.483986
Load Combination 1.2D + L	7	[7373, 15130]	7380	15120	0.066138	0.094851
	10	[7369, 15130]	7382	15120	0.066138	0.176104
	15	[7356, 15140]	7378	15120	0.132275	0.298184

Column *B* of table 31 lists the minimum and maximum span moment obtained from two typical load patterns (refer to earlier sections for details). Column *C* of table 31 shows percentage deviation of maximum span moment obtained from conventional analysis with upper bound on interval span moment. This percentage deviation in this particular case (beam 64) is not significant, however Figure 12a and 12b shows that this deviation is increasing as number of floors are increased, in fact for almost all the load combination that have been listed in table 31, this deviation build up to 300% as we increase number of floor from 7 to 15.



**Figure 12a. Maximum and Minimum Span Moment in Beam 64 - Percentage deviation Vs number of floor for load combination 1.2 D + 1.6 L**



**Figure 12b. Maximum and Minimum Span Moment in Beam 64 - Percentage deviation Vs number of floor for load combination 1.2 D + L**

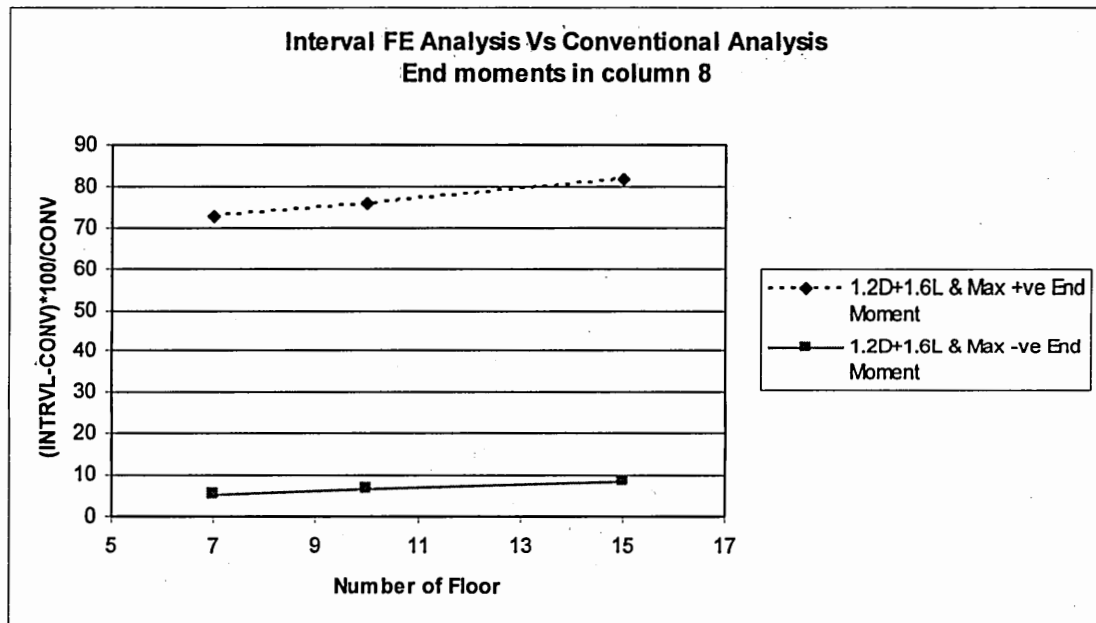
**Table 38. Column 8: (Interval result – Conventional Result)\*100/ Conventional Result Vs number of floor**

Comparison for Maximum End Moment		Comparison of Upper & Lower Bounds from Interval FE Analysis with corresponding Max & Min values for End Moment from Conventional Analysis						
Column 8		Conventional Analysis			Max +ve/-ve End Moment from Load Patterns		% Deviation	
Floors	Interval FE Analysis	Load Pattern A	Load Pattern B	Load Pattern C	Maximum +ve	Maximum -ve	Max +ve	Max -ve
	-Interval End Moment							
7	[-12193.5, 8515.77]	4927.87	-8307.41	-11568.9	4927.87	-11568.9	72.80	5.39
10	[-12495.5, 8541.63]	4847.61	-8464.98	-11687.2	4847.61	-11687.2	76.20	6.91
15	[-12968, 8579.49]	4715.4	-8662.33	-11923.8	4715.4	-11923.8	81.94	8.75
7	[-7730.38, 5212.92]	2970.49	-5301.56	-7339.97	2970.49	-7339.97	75.49	5.31
10	[-7835.82, 5312.4]	3003.64	-5316.73	-7330.61	3003.64	-7330.61	76.86	6.89
15	[-7957.64, 5509.52]	3094.46	-5266.62	-7305.02	3094.46	-7305.02	78.04	8.93
7	[-5563.06, 7380.24]	5137.8	-3134.25	-5172.65	5137.8	-5172.65	43.64	7.54
10	[-4857.24, 8290.98]	5982.22	-2338.15	-4352.03	5982.22	-4352.03	38.59	11.60
15	[-3613.85, 9853.3]	7438.25	-922.833	-2961.23	7438.25	-2961.23	32.46	22.03

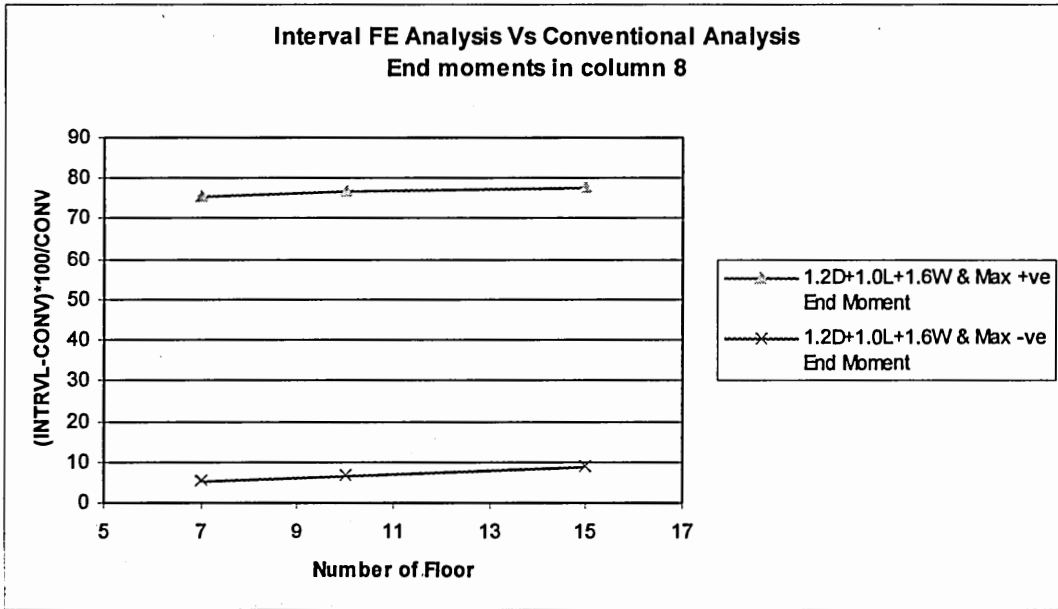
Comparison for Maximum End Moment	Floors	Comparison of Upper & Lower Bounds from Interval FE Analysis with corresponding Max & Min values for End Moment from Conventional Analysis							
		Column 8		Conventional Analysis			Max +ve/-ve End Moment from Load Patterns		% Deviation
		Interval FE Analysis	Load Pattern A	Load Pattern B	Load Pattern C	Maximum +ve	Maximum -ve	Max +ve	
		Interval End Moment	5109.36	-3162.69	-5201.09	5109.36	-5201.09	43.88	7.50
Load Combination 1.2D + L + E1	7	[-5591.51, 7351.79]							
	10	[-4887.83, 8260.4]	5951.64	-2368.74	-4352.03	5951.64	-4382.61	39.30	10.83
	15	[-3647.8, 9819.36]	7404.3	-956.777	-2995.18	7404.3	-2995.18	32.61	21.78

However, these trends become dominant when results obtained from column 8 are studied. Table 32 lists down interval end moment and end moment obtained from three different load pattern. In previous sections, results are shown for ten load combination, however for the time being only these four load combinations have been extracted as these are the best representative of all the load combinations in order to show the capability of Interval FE Analysis.

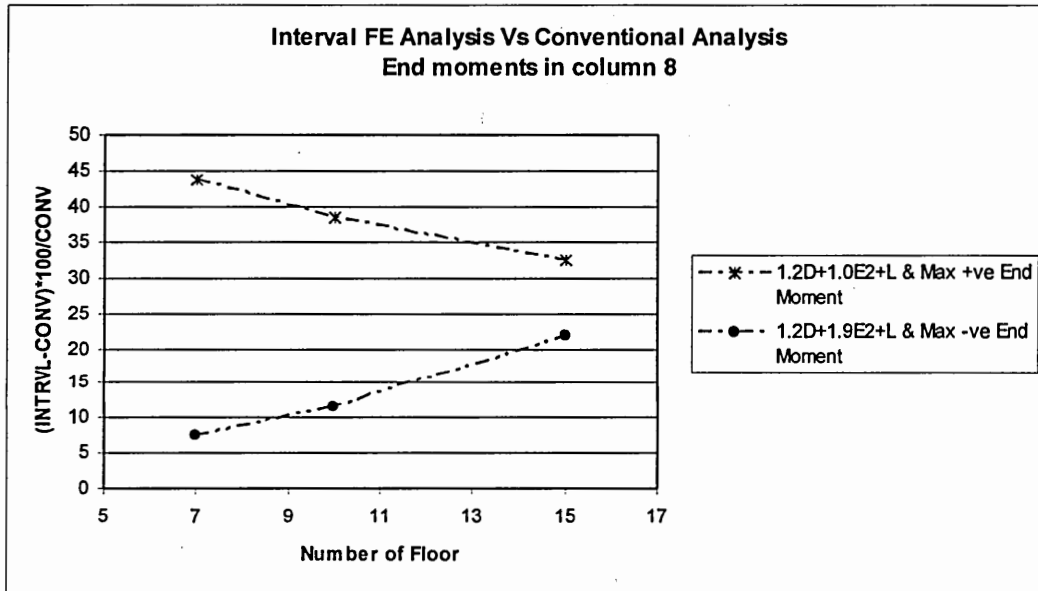
Once again interval end moment width increases as we increase number of floors. For load combination  $1.4D + 1.6L$ , deviation of maximum positive end moment from upper bound of interval end moment is quite significant, for seven floor frame it is about 72%, this indicate the fact that at times conventional structural analysis may prove to be very underestimating and results can be drastically wrong.



**Figure 13a. Bounds on End Moment in Column 8- Percentage Deviation Vs number of floor for load combination 1.2D+1.6L**



**Figure 13b. Bounds on End Moment in Column 8- Percentage Vs number of floor for load combination 1.2D+1.0L+1.6W**



**Figure 13c. Bounds on End Moment in Column 8- Percentage Deviation Vs number of floor for load combination 1.2D+1.0E2+L**

In this specific example the deviation of conventional result from interval bounds for end moment in column 8, does not build up to that extent as it was for beam element 64.

Table 32 shows that for  $1.2D+1.6L$ , deviation grow up from 72.8% only up to 81.9% as we move from seven-story frame to fifteen-story frame. For the load combination  $1.2D+L+E2$  and seven story frame, maximum negative end moment is about 7% of lower bound of interval end moment, and it grow up to 22% as we move to fifteen floor frame. However, for the same combination  $1.2D+L+E2$ , deviation of maximum end moment from upper bound of interval end moment drops from 43% to 32.5%, and such drops can be attributed to the nature of earthquake load involved in the load combination, however it is important to note that in situations where it deviate a lot, safety of structure is potentially threatening.

Additionally it is interesting to see that in order to capture exact critical scenario, interval FE analysis need only one interval run instead of running several load pattern. This can be verified as all the tables presented so far clearly show that the results obtained from conventional load pattern is strictly in between the lower and upper bounds of interval response. At the same time interval response will guarantee the enclosure of exact response within the sharp interval bounds. This kind of guarantee can never be assured by analyzing structure for few selected load patterns. Since interval response always contain all conventional structural analysis result that at times engineer would not even think to consider just because of the time and efforts needed, this is the most efficient and easiest approach available so far in order to find critical scenario for large and complicated real structures. Adoption of this technique in real analysis and design work will make life of an engineer a lot simpler and hence will help them in ensuring safety of large-scale structures.

## 10. Conclusions

The presented work shows that structural response obtained from interval finite element analysis bounds the structural response from conventional structural analysis for all possible load patterns. Load combinations that don't involve the presence of live load result in analyses that are identical as far as these two procedures (Interval finite element analysis and conventional load pattern analysis) are concerned. This is due to the fact that in such cases loads are considered completely deterministic and each method corresponds to one structural analysis iteration.

However due to presence of live load, a number of live load patterns come into picture and multiple analyses are needed. Since interval loads can capture all the combinations of presence and absence of individual load, interval finite element analysis gives a lower and upper bound on the structural response.

The difference between lower and upper bound can be related to the number of possible live load patterns. As we increase the number of floors in a frame, the numbers of load patterns also increases. In the current thesis work, it has been verified that the width of interval increases as we increase number of floors.

The structural response obtained from a few selected live load patterns is not necessarily a critical scenario for all the design parameters that an engineer may need in a design. Thus, unless a complete load pattern analysis is done, the critical response predicted through such load patterns can vary significantly from the actual critical response. However the lower or/and upper bound of interval response if used in design practices,

will ensure that correct values of all the design parameters are used. In such cases, design will be more accurate and economic.

The deviation of conventional load pattern analysis results from the bounds of interval response is independent of structural element type. It does not make any difference which structural element is picked up as the design element.

Additionally all the structural parameters like span moments, end moments, shear force, axial force and joint displacements can be evaluated for lower and upper bounds through interval finite element analysis. Since all the parameters obtained in one run show interval enclosure on all the critical scenarios obtained from different load pattern analysis, interval finite element analysis proves to be very efficient as compared to conventional load pattern analysis.

Interval finite element analysis provides a way to combine all the load patterns and load combinations through interval load factors and interval load. In current thesis work results obtained using interval load factors and interval loads are highly conservative as interval load factors has been formulated in a crude way. A more complex formulation for interval load factors would result in a much sharper interval response.

## APPENDIX A

Here is the computer program written in C++ for analyzing a portal frame under joint load and continuous loads and for load combination using interval finite element technique. Chapter 6 discusses this program in details. Here is the computer code attached.

```
//Load Combination Frame finite element program
//use conventional FEM formula for BASIC
//LOAD: interval nodal load and element uniform load
//use PROFIL to solve the system equation
// by Dr. Rafi Muhanna / Hao Zhang / Vishal Saxena
// June 25, 2002

#include "intmat.h"
#include "util.cpp"
#include "func.h"
#include <iostream.h>
#include <fstream.h>
#include <stdio.h>
#include <math.h>

class FRAME
{
protected:
    int NELE;//number of elements
    int NNOD;//number of nodes
    char* filename;//the inputdata filename

    MATRIX mNode_info;
    //node information, store:node number,support information,x and y coordinates
    //MATRIX mEleInfo;//element connectivity and element uniform load,store: ele
    //number, connectivity, and uniform distribute load( positive, if the element
    //direction counterclockwise 90 to the uniform load direction)
    MATRIX mEleInfo;//element connectivity
    //MATRIX mNodalLoad;//nodal external load, store: x,y and theta 3 terms
    //repectively
    //Dead Load
    INTERVAL_VECTOR ivEleLoadDL;//element load,in our program, only
    //interval uniform load are allowed
    //Live Load
    INTERVAL_VECTOR ivEleLoadLL;//element load,in our program, only interval
    //uniform load are allowed
```

```

//Earthquake Load : EQ coming from one direction
INTERVAL_MATRIX imNodalLoadEL;//interval nodal load, x y and theta
//Wind Load
INTERVAL_MATRIX imNodalLoadWL;//interval nodal load, x y and theta
//Load factor
INTERVAL_VECTOR loadFactor ;
INTERVAL_VECTOR ivPc;//assembled system nodal load,only include the
external loadal load
INTEGER_MATRIX IBOU;//record boundary conditions, 0:fixed, 1: free
MATRIX GSTF;
MATRIX mMaterial;//material, include: A,I and E
MATRIX mMatrix;//m matrix
MATRIX mMatrix_noBC;//m matrix without BC imposed, used in element force
calculation
INTERVAL_VECTOR ivDisplacement;//nodal displacement
INTERVAL_VECTOR LOAD_EBE_expand;//nodal load, assembled by imPc
public:
FRAME();
void InitialData();//used in constructor
void ReadData();
void Boundary();//construct IBOU,used in Calculation()
void Calculation();//assemble GSTF, calculate displacement, and element internal
forces
void ElementForce();//calculate element force
MATRIX Estf_Calculation( int );//this function return the element stiffness
MATRIX M_Matrix_Calculation();
};

FRAME::FRAME()
{
    filename=new char[100];
    InitialData();
    Resize(mNode_info,NNOD,6);//stor the node number,support infor, x coordinate
and y coordinate
    Clear (mNode_info);
    Resize(mEleInfo,NELE,3);//store the ele #, connectivity
    Clear (mEleInfo);
    Resize (mMaterial,NELE,3);//store the A,I,E
    Clear (mMaterial);

    Resize (ivEleLoadDL,NELE);//store the interval dead load terms on x,y,theta
dofs, respectively
    Clear (ivEleLoadDL);
}

```

```

Resize (ivEleLoadLL,NELE);//store the interval live load terms on x,y,theta dofs,
respectively
Clear (ivEleLoadLL);

Resize (imNodalLoadEL,NNOD,3);//store the interval earthquake load terms on
x,y,theta dofs, respectively
Clear (imNodalLoadEL);

Resize (imNodalLoadWL,NNOD,3);//store the interval wind load terms on
x,y,theta dofs, respectively
Clear (imNodalLoadWL);

Resize(loadFactor,4);
Clear(loadFactor);

Resize (ivPc,NNOD*3);
Clear (ivPc);

Resize (GSTF,NNOD*3,NNOD*3);
Clear (GSTF);

Resize (mMatrix,NNOD*3,NELE);
Clear (mMatrix);

Resize (mMatrix_noBC,NNOD*3,NELE);
Clear (mMatrix_noBC);

Resize (IBOU,NNOD,3);
Clear (IBOU);

}

void FRAME::InitialData()
{
    ifstream INFILE;
    char *string=new char[80];
    cout<<"please specify the input data filename."<<endl;
    scanf("%s",filename);
    INFILE.open(filename,ios::in|ios::nocreate,1);
    if (! INFILE){//in case the mistyped data file name
        cout<<"Data file does not exist! program terminated, please try
        later!"<<endl;
        exit(0);
    }

    INFILE.getline(string,80);

```

```

    INFILE.getline(string,80);
    INFILE >> NNOD>>NELE;//number of elements,number of nodes

    INFILE.close();
}

```

```

void FRAME::ReadData()
{

```

```

    ifstream INFILE;
    INFILE.open(filename,ios::in,1);
    char *string=new char[180];
    INFILE.getline(string,180);//eliminate the first comment line
    INFILE.getline(string,180);
    INFILE >> NNOD;
    INFILE >> NELE;
    INFILE.getline(string,180);
    INFILE.getline(string,180);
    INFILE >> mNode_info;
    INFILE.getline(string,180);
    INFILE.getline(string,180);
    INFILE >> mEleInfo;
    INFILE.getline(string,180);
    INFILE.getline(string,180);
    INFILE >>mMaterial;
    //Dead Load Information
    INFILE.getline(string,180);
    INFILE.getline(string,180);
    INFILE >>ivEleLoadDL;
    //Live Load Information
    INFILE.getline(string,180);
    INFILE.getline(string,180);
    INFILE >>ivEleLoadLL;
    //Earthquake Load Information
    INFILE.getline(string,180);
    INFILE.getline(string,180);
    INFILE >>imNodalLoadEL;
    //Wind Load Information
    INFILE.getline(string,180);
    INFILE.getline(string,180);
    INFILE >>imNodalLoadWL;
    //Load Factor Information
    INFILE.getline(string,180);
    INFILE.getline(string,180);
    INFILE >>loadFactor;
    INFILE.close();
}

```

```

}

void FRAME::Boundary()
{
    Clear (IBOU);
    for (int i=1;i<=NNOD;i++)
        for (int j=1;j<=3;j++)
            IBOU(i,j)=int (mNode_info(i,j+1));
}

MATRIX FRAME::Estf_Calculation(int IE)
{
    VECTOR vQie(6);
    MATRIX ESTF(6,6);
    MATRIX ESTT(6,6);
    Clear (ESTT);
    Clear (ESTF);
    int I1= int(mEleInfo(IE,2));
    int I2= int(mEleInfo(IE,3));

    double X1= mNode_info(I1,5);
    double Y1= mNode_info(I1,6);
    double X2= mNode_info(I2,5);
    double Y2= mNode_info(I2,6);

    double AL= Sqrt(Sqr(X2-X1) + Sqr(Y2-Y1));
    double AA = mMaterial(IE,1);// material const: A (area of the element)
    double AI = mMaterial(IE,2);//material const: I (moment of inertia)
    double AE = mMaterial(IE,3);//material const: E (elastic modulus)

    ESTF(1, 1) = AA*AE/AL;
    ESTF(4, 1) = - ESTF(1, 1);
    ESTF(2, 2) = 12.0*AE*AI/(AL*AL*AL);
    ESTF(3, 2) = 6.0*AE*AI/(AL*AL);
    ESTF(4, 2) = 0.0;
    ESTF(5, 2) = -ESTF(2, 2);
    ESTF(6, 2) = ESTF(3, 2);
    ESTF(3, 3) = 4.0*AE*AI/AL;
    ESTF(5, 3) = -ESTF(3, 2);
    ESTF(6, 3) = ESTF(3, 3)/2.0;
    ESTF(4, 4) = ESTF(1, 1);
    ESTF(5, 5) = ESTF(2, 2);
    ESTF(6, 5) = ESTF(5, 3);
    ESTF(6, 6) = ESTF(3, 3);
}

```

```
//calculate the element stiffness, 6x6,beam element, see the fomula of structural mechanics PP317
```

```
int k=1;  
for (int i = 1; i <= 6; i++,k++){  
    for(int j= k; j <= 6; j++){  
        ESTF(i, j) = ESTF (j, i);  
    }  
}
```

```
//symetric element stiffness
```

```
double CO = (X2-X1)/AL;  
double SI = (Y2-Y1)/AL;  
MATRIX T (6,6);  
Clear (T);  
T(1, 1) = CO;  
T(2, 1) = -SI;  
T(1, 2) = SI;  
T(2, 2) = CO;  
T(3, 3) = 1.0;  
T(4, 4) = CO;  
T(5, 4) = -SI;  
T(4, 5) = SI;  
T(5, 5) = -SI;  
T(4, 5) = SI;  
T(5, 5) = CO;  
T(6, 6) = 1.0;//calculate the transformation matrix
```

```
ESTT = Transpose(T) * ESTF * T;  
vQie(1)=vQie(4)=0.;  
vQie(2)=vQie(5)=AL/2;  
vQie(3)=AL*AL/12;  
vQie(6)=-AL*AL/12;
```

```
INTEGER_MATRIX IBOU_ELE (2, 3);  
Clear (IBOU_ELE);
```

```
for ( int j=1;j<=3;j++){  
    IBOU_ELE(1,j)=IBOU(I1,j);  
    IBOU_ELE(2,j)=IBOU(I2,j);  
}
```

```
vQie=Transpose(T)*vQie;  
for (i=1;i<=3;i++){  
    mMatrix_noBC((I1-1)*3+i,IE)=vQie(i);  
    mMatrix_noBC((I2-1)*3+i,IE)=vQie(i+3);  
}
```

```

vQie=T*vQie;
for (i=1;i<=2;i++)
for (int j=1;j<=3;j++)
if (0==IBOU_ELE(i,j)) vQie((i-1)*3+j) = 0.;
vQie=Transpose(T)*vQie;
for (i=1;i<=3;i++){
    mMatrix((I1-1)*3+i,IE)=vQie(i);
    mMatrix((I2-1)*3+i,IE)=vQie(i+3);
}
return ESTT;
}

void FRAME::Calculation()
{
    //here to get the material information
    //here to get the nodal load information
    int NDOF = 3 * NNOD;
    VECTOR vP(NDOF);
    Clear (vP);

    //system stiffness matrix
    //now do element loop, to calculate the element stiffness->assembly to system
    stiffness matrix;
    for (int IE=1;IE<=NELE;IE++){
        MATRIX ESTT(6,6);
        ESTT = Estf_Calculation(IE);
    }
}

//=====
// Assembling the Global Stiffness Matrix, and load vector vP
int I1= int(mEleInfo(IE,2));
int I2= int(mEleInfo(IE,3));
INTEGER_VECTOR LM(6);
Clear (LM);
for (int I=1;I<=3;I++){
    LM(I)=I + 3*I1-3;
    LM(I+3)= I + 3*I2-3;
}
for (I=1;I<=6;I++){
    int NN= LM(I);
    //vP(NN)+=Pe(I);
    for (int J=1;J<=6;J++){
        int MM=LM(J);
        GSTF(NN,MM)+=ESTT(I,J);
    }
}
}

} //the end of element loop, here we get GSTF

```

```

//Next to introduce BC in GSTF to eliminat the singularity of GSTF
// rows and columns corresponding
// to the restrained ith DOF are zeros, GSTF(i,i)=1
    for (int I=1;I<=NNOD;I++){
        for (int J=1;J<=3;J++){
            int MM=IBOU(I,J);
            if (0==MM){
                int K=3*I-3+J;
                for (int mm=1; mm<=NDOF;mm++){
                    GSTF(mm,K)=0.;
                    GSTF(K,mm)=0.;
                }
                GSTF(K,K)=1.;
            }
        }
    }

INTERVAL_VECTOR U(NDOF);
INTERVAL_VECTOR U1(NDOF);
INTERVAL_VECTOR U2(NDOF);

for (int i=1;i<=NNOD;i++){
    for (int j=1;j<=3;j++){
        int NN=(i-1)*3+j;
        int MM=IBOU(i,j);

        ivPc(NN)=loadFactor(2)*imNodalLoadEL(i,j)+loadFactor(4)*imNodalLoadWL(I
        j);
        if(0==MM){
            ivPc(NN)=0.;//assemble nodal load
        }
    }
}

//now we have GSTF and ivPc,and introduced BC, next , to get displacement
// COMPUTATION OF SYSTEM DISPLACEMENTS
//U=Inverse(GSTF)*(ivPc+mMatrix*ivEleLoadLL);//have overestimation??!!
U1=Inverse(GSTF)*ivPc;

U2=Inverse(GSTF)*mMatrix*(loadFactor(1)*ivEleLoadDL+loadFactor(3)*ivEle
LoadLL);
U=U1+U2; //Displacement for current Load Combination

```

```

fstream Uoutput;
Uoutput.open("U-ISA-OUT.TESTEX2.txt",ios::out,1);
Uoutput<<"now output the interval nodal displacement."<<endl;
for (int IN=1;IN<=NNOD;IN++){
    Uoutput<<"Node: "<<IN<<" ";
    for ( int i=1;i<=3;i++)
        Uoutput<<U((IN-1)*3+i)<<" ";
    Uoutput<<endl;
}
Uoutput.close();
}

void FRAME::ElementForce()
{
    int NDOF = 3 * NNOD;

    //Added by Vishal Saxena : 07/05/2003
    //Parameters used in order to compute maximum Bending Moment within
    the span of beam - Start
    MATRIX EL(6,NELE);
    VECTOR R1(NELE);
    VECTOR R2(NELE);
    VECTOR R3(NELE);
    VECTOR R4(NELE);
    VECTOR R5(NELE);
    REAL dist;
    REAL D;
    INTERVAL max, max1, max2;
    //Parameters used in order to compute maximum Bending Moment within
    the span of beam - End

    fstream Feoutput;
    Feoutput.open("F-ISA-OUT.TESTEX2.txt",ios::out,1);
    Feoutput<<"now output the interval element interval force"<<endl;

    for (int IE=1;IE<=NELE;IE++){
        //if(IE == 8 || IE == 64){
        INTERVAL VECTOR ivEF(6);//element force
        INTERVAL iEleLoad;

        iEleLoad=loadFactor(1)*ivEleLoadDL(IE)+loadFactor(3)*ivEleLoadLL(IE) ;
        int el=(iEleLoad!= 0)?1:0;
        int I1= int(mEleInfo(IE,2));
        int I2= int(mEleInfo(IE,3));
    }
}

```



```
int main()
{
    FRAME* pFRAME=new FRAME();
    pFRAME->ReadData();
    pFRAME->Boundary();
    pFRAME->Calculation();
    pFRAME->ElementForce();
    delete pFRAME;
    return 0;
}
```

## REFERENCES

- Alfred, G., and Herzberger, J. (1983). Introduction to interval computations. Academic, New York.
- Apostolatos, N., and Kulisch, U. (1968). "Grundzuge einer Intervallrechnung fur Matrizen und einige Anwwendungen, Elektron. Rechenanlagen, 10, 73-83 (in German).
- Bleher, J.H., Rump, S.M.,Kulisch, U.W., Metzger, M.Ullrich, Ch., and Walter, W.(1987). "FORTRAN-SC: A study of a FORTRAN extension of engineering/scientific computations with access to ACRITH." *Computing*, 29, 93-110.
- Building Code Requirements for Structural Concrete (ACI 318-02) and Commentary (ACI 318R-02), American Concrete Institute, Farmington Hills, MI
- Center of Reliable Computing, Georgia Tech Regional Engineering Program (GTREP) Savannah.
- Dwyer, P.S., ed.(1951). Computation with approximate numbers, linear computations, Wiley, New York, 11-34.
- Hansen, E. (1965). "Interval arithmetic in matrix computation." *SIAM J.,numer. Anal.*, 19(4), 858-870
- Hansen, E. (1992). Global optimization using interval analysis. Marcel Dekker, New York.
- International Building Code (2000), Chapter 16, Structural Design, International code council.
- Introductory Problems in Structural Analysis, an article accessible at <http://www.public.iastate.edu/~fanous/ce332/influence/homepage.html>
- Jansson, C. (1991). "Interval linear system with symmetric Matrices, Skew-Symmetric matrices, and dependencies in the right hand side." *Computing*, 46, 265-274
- Köyluoglu, H.U., Cakmak, A.S., and Nielsen, S.R.K. (1995). "Interval algebra to deal with pattern loading and structural uncertainty *Journal of Engineering Mechanics.*, ASCE, 121(11), 1149-1157.
- Köyluoglu, U., and Elishakoff, I. (1998). "A comparison of stochastic and interval finite elements applied to shear frames with uncertain stiffness properties." *Comp. and Struct.*, 67(1-3),91-98

- Mayer, O. (1970). "Algebraische und metrische Strukturen in der Intervallrechnung und einige Anwendungen." *Computing*, 5, 144-162 (in German).
- Minimum Design Loads for Buildings and Other Structures (ASCE7-2002), American Society of Civil Engineers
- Moor R.E.(1966). *Interval analysis*. Prentice-Hall, Englewood Cliffs, N.J.
- Muhanna, R. L. and Mullen, R. L. (1995). "Development of interval based methods for fuzziness in continuum mechanics." *Proc. ISUM A-NAFIPS '95*, IEEE Computer Society Press, Los Alamos, Calif., 145-150.
- Muhanna, R. L. and Mullen, R. L. (1999). "Formulation of fuzzy finite element methods for mechanics problems." *J. Comp.-Aided Civ. And Infrastructure Engrg.*, 14, 107-117.
- Mullen, R. L. and Muhanna, R. L. (1996). "Structural analysis with fuzzy-based load uncertainty." *Proc., 7<sup>th</sup> ASCE EMD/STD Joint Spec. Conf. on Probabilistic Mech. and Struct. Reliability*, WP I,MA, ASCE, New York, 310-313
- Mullen, R. L. and Muhanna, R. L. (1999). "Bounds of Structural Response for All Possible Loading Combinations", *Journal of Structural Engineering*, Vol. 125, No. 1, January 1999.
- Neumaier, A. (1987). *Interval methods for system of equations*, Cambridge University Press, New York.
- Nilson, A.H., and Winter, G. (1991) "Design of concrete structures", McGraw-Hill, New York.
- Rao, S.S., and Berke, L. (1997). "Analysis of uncertain structural systems using interval analysis." *AIAA J.*, 35(4), 727-735
- Rao, S.S., and Chen, Li. (1998). "Numerical solution of fuzzy linear equations in engineering analysis." *Int. J. Numer. Methods in Engrg.*, 43, 391-408.
- Rao, S.S., and Sawyer, P. (1995). "Fuzzy finite element approach for analysis of imprecisely defined systems." *AIAA J.*, 33(12), 2364-2370
- Sunaga, T. (1958). "Theory of interval algebra and its application to numerical analysis." *RAAG Memoirs* 3, 29-46
- Uniform building code. (1998). *International Conference of Building Officials*, Whittier, Calif., 126.
- Zadeh, L.A. (1965). "Fuzzy sets." *Information and Control*, 8, 338-353